

www.fine-tek.com

Monitoring Devices For Conveyor System



CONVEYOR BELT MISALIGNMENT SWITCH FOR PROTECTION OF BELT CONVEYORS AND PERSONNEL



TS Ex tb IIIC T85°C Db
NEPSI Ex tD A21, IP67 T85°C
IECEx Ex tb IIIC T85°C Db

SRT

This device monitors the operation process for potentially hazardous conditions and activate an alarm when it is occurred misalignment, the SRT series conveyor belt misalignment switch protects the conveyor belt from damage due to belt misalignment or run off.

For normal condition, the belt misalignment switches are generally mounted on both sides and the edge of the conveyor belt.

A small clearance between the contact rollers and a little swaying for the belt edges are allowable.

When the swaying exceeds the normal limit (on/ about 20 mm), the belt edge pushes the contact roller, which drives the switch and operates the contacts, the misalignment switch will reset automatically when the belt resumes normal running. These control devices are used in pair on both side of conveyor belt detected place, each unit can be equipped with two micro-switches to produce signals indicating the belt misalignment at two deviation points.

The first signal point could indicate small belt deviation by output an alarm, the second signal point could guard against extreme belt run off by shutting down the conveyor.

The roller is adjustable up to 20° in both directions and is positioned approximately 20mm from the conveyor belt, the switch actuation points are adjustable from 0° to 35° by a simple change of the actuating cams.

FEATURES

- Easy Installation, operation sensitive
- Roller arm can move up to 75 degrees in either direction
- Dust tight, IP 67 weatherproof, Die cast aluminum housing
- Roller lever actuating angle 20° for alarm signal and 35° for shutting down system
- To Save Process downtime, product loss and replacing cost of damaged conveyor belt
- SRT-170, Explosion-proof

SPECIFICATION

Switching Capacity	15A 125/250Vac, 5A 30Vdc SPDT×2 (standard) 10A 125/250Vac, 5A 30Vdc DPDT×2 (order)
Operating torque	3.4~5.4N.m (0.35~0.55kgf.m)
Reset Way	Auto
Ambient Temp.	-20~60°C (Explosion protection environment: -20~50°C)
Enclosure Protection Grade	IP67
Enclosure Material	Die cast ADC
Weight	Approx. 2.8kg

DIMENSION

SRT

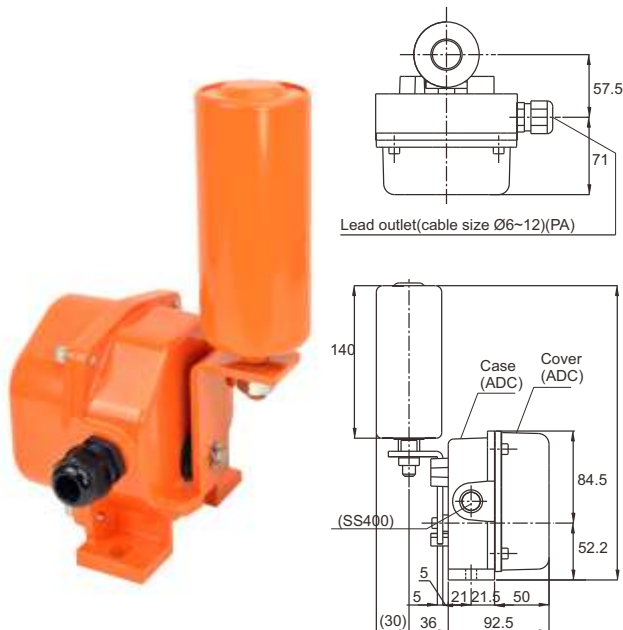

APPLICATIONS

- Conventional Belt Conveyors
- Underground, Cable Supported Belt Conveyors
- Stacker / Reclaimer Conveyors
- Ship Loading / Unloading Systems
- Tripper and Shuttle Conveyors
- Crane / Shovel Boom Position Limit Detector
- Apron Feeders & Conveyors
- Heavy Duty Limit Switch

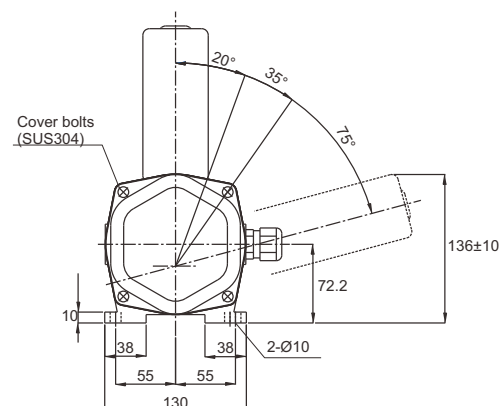

SAFETY CABLE PULL SWITCH FOR EMERGENCY OR NORMAL SHUT-OFF

SRS

Belt conveyor safety cable pull switches are designed for providing a switching system to isolate the power to conveyor system and other equivalent process equipment in the emergency condition.

The cable pull switches are actuated by a plastic coated steel wire, which are placed along-side the conveyor. When you pull on the cable at any point, it will trip and automatically lock the switches, deenergizing the conveyor starter contactor. Each switch is bi-directional in operation and has two cable fitted to it from opposite directions terminated with a spring at the anchor points, please see drawing 4 the springs will operate the switch on cable breakage.

After tripping the mechanical latch can be released only on the switch itself by the reset lever.

APPLICATIONS

emergency or normal stop for below facilities

- Conventional Belt Conveyors
- Shuttle Conveyors
- Bucket Elevators
- Packaging Lines
- Stockpile/Reclaim systems, Cranes, Shovels, Draglines
- Ship Loading / Unloading System
- Horizontal Feed Systems

DIMENSION

SRS

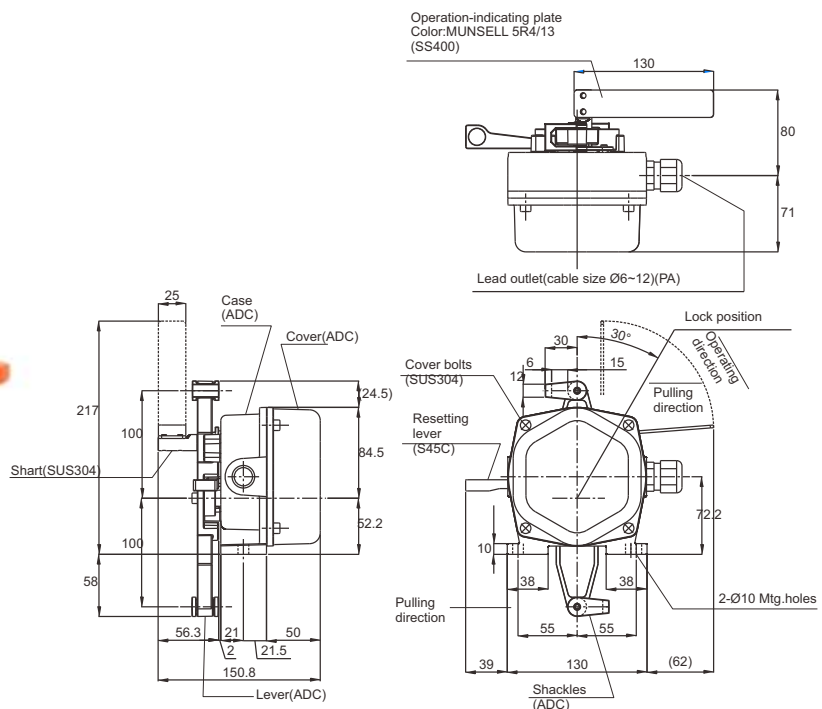

FEATURES

- Universal design for bi-direction activation
- Compact design for tight-fit areas, IP67 rugged die cast aluminum housing
- Manual reset lever
- Easily orientated at either end or intermediate position in pull cable run
- Cable Pull 30° for shutting down system
- Highly visible black arm easily shows condition of the switch, indicating alarm or normal
- SRS-170, Explosion-proof

SPECIFICATION

Switching Capacity	15A 125/250 Vac , 5A 30 Vdc SPDTx2
Operating torque	49 ± 9.8N (5 ± 1kgf)
Reset Way	Manual
Ambient Temp.	-20~60°C (Explosion protection environment: -20~50°C)
Enclosure Protection Grade	IP67
Enclosure Material	Die cast ADC
Weight	Approx. 2.2kg

MODEL NUMBER / ORDER CODE COMPARISON TABLE / ORDER INFORMATION

SRT Conveyor Belt Misalignment Switch

Model Number	Order Code
SRT-100	SRT20000
SRT-170	SRT200□D

SRT 2 0 0 ⁰⁷□ ⁰⁸□ - ⁰⁹□ ¹⁰□ ¹¹□ ¹²□

07 08 Certification

- 00: None
- 2D: IECEX-Ex tb
- 5D: TS-Ex tb
- 7D: NEPSI-Ex tD

09 10 11 12 Conduit

- A503: 1/2"PF
- A507: 1/2"NPT(Standard)

SRS Safety Cable Pull Switch

Model Number	Order Code
SRS-100	SRS20000
SRS-170	SRS200□D

SRS 2 0 0 ⁰⁷□ ⁰⁸□ - ⁰⁹□ ¹⁰□ ¹¹□ ¹²□

07 08 Certification

- 00: None
- 2D: IECEX-Ex tb
- 5D: TS-Ex tb
- 7D: NEPSI-Ex tD

09 10 11 12 Conduit

- A503: 1/2"PF
- A507: 1/2"NPT(Standard)

SPEED MONITOR-EDX4



NEPSI Ex tD A21, IP65 T85°C

EDX4 Speed Monitor is a totally new rotational speed monitoring equipment; it uses the principle of photo detector and microprocessor to accurately calculate a wide range of rotational speed. It detects rang 1~999rpm and the rotational speed display on 7-seg led.

There is a contact relay that could be used either for alarm or control purposes during the monitoring process. The alarm set point could be directly set by numerical knobs which is more convenient and more accurate than conventional means. It comes equipped with analog signal output which could be utilized for various display indications and more precise control. It is ideal for applications in monitoring low speed, stop and overload situations.

APPLICATION

- Low speed and overload protection monitoring of various conveyer systems
- Networked circuits to form sequential start or stop
- Frequently used machines: Grain and coal storage bucket elevators and belt conveyer machines

SPECIFICATION

- Measuring Range : 0~999 rpm.
 - 7-seg led display 0~999
 - Alarm Set point : 1~999 rpm by rotary switch.
 - Alarm Conditions : Underspeed, standstill, power failure.
 - Startup Delay : 0 second or 15 Seconds. Selectable
 - Alarm Contact Rating : SPDT 5A/250Vac.
 - Alarm Delay : 0, 3, 6, 9,...,27 seconds. Selectable
 - Speed Analog Output : 4~20mA
(Signal Range Selectable : 100/200/500/1000rpm).
 - Power Supply : 100~240Vac,50/60Hz
 - Power Consumption : 6VA.
 - Operating Temperature : -20°C~70°C.
 - Housing : Cast Aluminum.
 - Protection : IP65
- Cable Entry : 1/2"NPT X 2 hole.

FEATURES

- Maximum monitoring range 1~999rpm.
- 7-seg led display 0~999
- Alarm monitoring: low speed, stop, reverse, blackout and overload.
- Start up delay function allow motor to run up gradually.
- Alarm delay function can avoid fault alarm which many caused by temporary slow down or load changed.
- Selectable rotate direction for both CCW and CW makes installation more versatile.
- Light pulses are not affected by environmental conditions.
- Complementary to FineTek PB/PM series digital Panel meter to indicate speed.

Special Function (built in function)

4~20mA output, proportional to selectable speed range like 100rpm, 200rpm, 500rpm and 1,000rpm.

DIMENSIONS

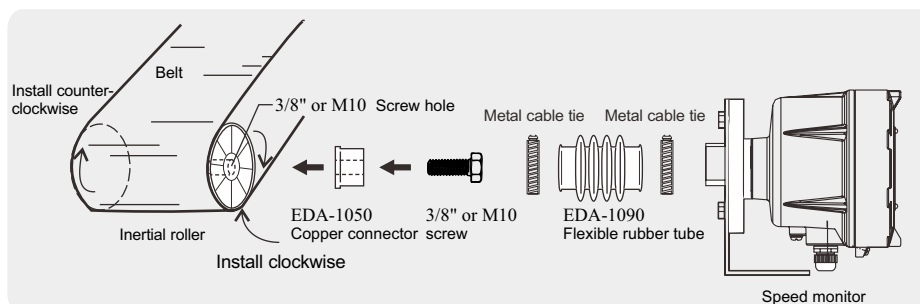
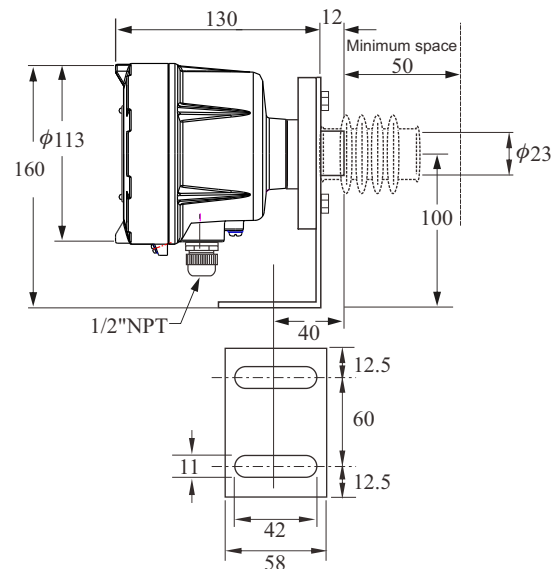

SPEED MONITOR- EDX1



NEPSI Ex tD A21, IP65 T85°C

WORKING PRINCIPLE

EDX1 is a brand new speed monitoring device exclusively designed for a belt conveyor, which monitors the rotation speed by using the optoelectronic switch or magnetic induction part. During this process, it provides an output contact SPDT for alarm or control. The alarm setting is determined by the scale on the adjustment knob, which is convenient and fast. Based on the conventional analog design, it uses a simple, stable and low-cost circuit, which makes it economical.

SPECIFICATION

Working power supply	110 VAC or 220 VAC $\pm 20\%$, 50/60 Hz , 24VDC $\pm 10\%$
Speed measurement range	0~150 rpm
Rotation direction	Can monitor clockwise and counter-clock wise directions simultaneously
Alarm condition	Overly-low rotation speed then stops
Startup delay time	0-second or 30-second switch
Output type	Relay output 1SPDT
Contact capacity	5A / 250VAC, 5A / 30VDC
Working temperature	-40°C~85°C
Housing material	Aluminum alloy, baked finish
Connection of inlet port	1/2"NPT housing protection level: IP-65
Reproducibility of alarm setting	$\pm 5\%$

DIMENSIONS

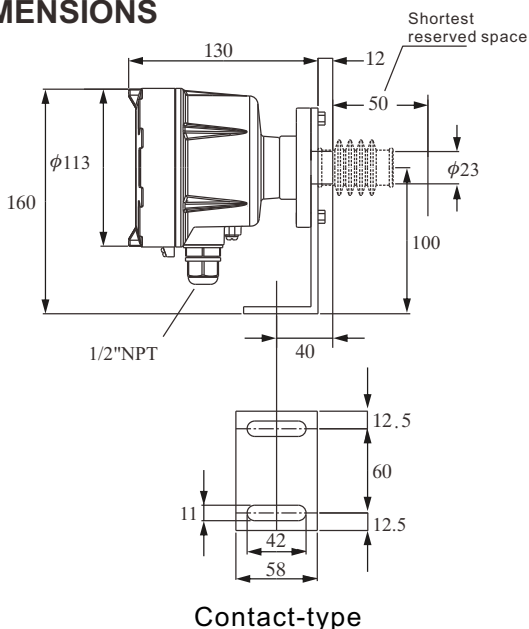

FEATURES

- The alarm point setting of the speed monitor adopts a knob type operation, which is simple and fast.
- Based on the field application requirements, you may select the startup delay alarm function, so as to prevent false alarm when the device is accelerating at startup.
- Status indicator is clear, so user may determine whether the current rotation speed is normal.
- Universal relay output type is used, which doesn't require complicated wiring procedure.
- The output delay function can avoid false alarm when the rotation speed is fluctuating at the moment of material dropping.
- Contact and non-contact structural design are available, so user may select proper installation type based on the field requirements.

APPLICATION

It is widely applied in the industrial fields such as metallurgy, quarry, cement, steel, port, grain, power, pulp & paper, and resource recycling, which is used for monitoring protection of skid, overly-low speed and overload of various belt conveyors. When applied in the chain line, it can make up sequential startup or stop.

For instance:

- Conventional belt conveyor
- Chain cableway conveyor
- Reciprocating conveyor
- Bucket elevator
- Ring apron conveyor
- Plate feeding conveyor
- Material piling/taking system, crane, excavator
- Conveying belt of coal feeder
- Ship loading/unloading system
- Horizontal feeding system
- Packaging production line of the manufacturing industry

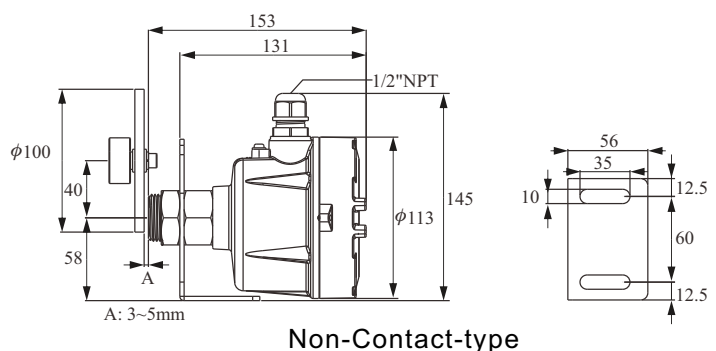

PANEL CONFIGURATION DIAGRAM

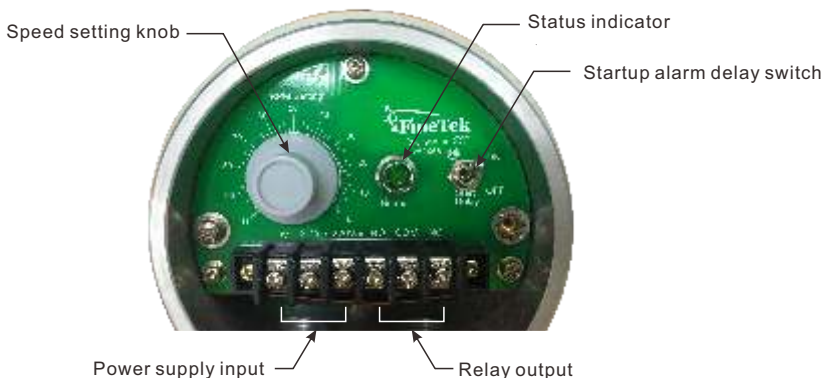

INSTALLATION INSTRUCTION

Contact type

Tap the 3/8" (or M10) screw hole in a central towards the axis direction of the driven wheel on the device to be monitored; fasten the copper connector on the rotation axis with the screw. And then set up a scaffold in front of the reversed rotation axis, align the axis center of the speed monitor and the driven wheel, and then fix it. Finally, connect with the rubber bellow and fasten the metal straps to finish the installation.

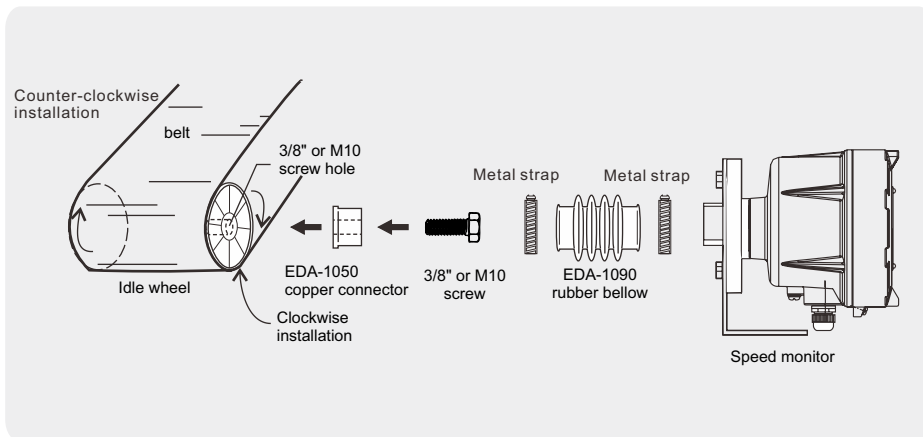

Non-contact type (Wheel axis tapping)

Tap the 3/8" (or M10) screw hole from the center towards the axis of the driven wheel on the device to be monitored, and then fix the sensing plate with screws. When fixing, it needs to go through the flat washer and spring washer. Fix the machine body on the corresponding position with the fixing plate. Finally, keep a 3~5mm distance between the probe in front of the body and the sensing plate to finish the installation.

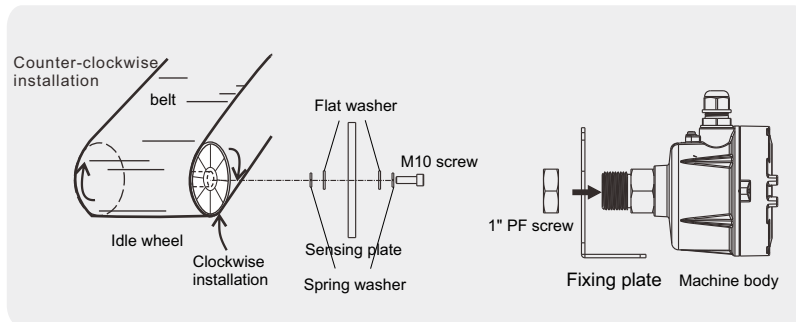

MODEL NUMBER / ORDER CODE COMPARISON TABLE / ORDER INFORMATION

Model Number	Order Code
ED4000	EDX40000-0CR
EDX10	EDX10000-□□R

EDX ⁰⁴□ ⁰⁷0 ⁰⁸0 ⁰⁹□ ¹⁰□ R

04 Version(Features)

- 1: Analogy speed monitor
- 4: Display speed monitor

07 08 Certification

- 00: None
- 7D: NEPSI-Ex tD

09 Sensing mode

- 0: Contact type
- 1: Non-Contact type (Only analogy speed monitor)

10 Power supply

- J: 110/220Vac,50/60Hz (Only analogy speed monitor)
- D: 24Vdc (Only analogy speed monitor)
- C: 100~240Vac (Only display speed monitor)