



Vibrating Probe Level Switch



visit our website

PRODUCT INTRODUCTION

WORKING PRINCIPLE

The Finetek vibrating probe switch is highly versatile and can be used for most almost any bulk solid application. This includes level detection of almost any granular, sandy, chip like, foodstuff, grain or powdery materials.

The operating principle is based on the changes of vibration frequency of the tuning fork when it comes into contact with a liquid or solid material..

The Vibrating probe contains piezoelectric crystals built into the vibration tube that produce vibrations/resonations at specific frequencies. One element acts as a transmitter of the signal and the other receives the signal and converts it to electrical output.

When the Vibrating probe comes in contact with material the vibration is weakened/dampened and results in a frequency change which triggers the switch. It's ideal for applications where: the dielectric constant is low (where capacitance level switches can't be used) ; when material moisture content changes easily; low viscosity liquids; there is a combination of differing materials in the container/tank.

The Vibrating probe provides a reliable & maintenance-free means of process control for bulk solids. Easy mounting at almost any angle and basic calibration procedures will provide reliable functioning and less required monitoring. This device can withstand tough lateral loads and static electricity.

Furthermore, it eliminates the application issues associated with jamming and clogging between tines on a 'tuning fork' device Also; it is equipped with a Fail-safe that prevents malfunctioning caused by power cuts

FEATURES

- Transparent panel cover for viewing the power supply and output
- Voltage supply range 20~250, 50~60Hz Vac/ Vdc.
- SPDT Relay output, SSR MOSFET output.
- Sensitivity adjustment is available for different density mediums.
- Low wear and tear, maintenance free and self cleaning.
- Fine powders can be detected.
- Euro, Multifunctional and UL certified Models available

APPLICATION

Solid Level Detection

Powders:

Powdered milk, flour, spices, coffee beans, coffee powder, tea, salt, sugar, grains, chocolate
Tobacco, powdered cellulose, powdered clay, polystyrene powder, dry soot, soda ash, coal ash

Granular & plastics:

Gravel, glass fine power, granular plastics, foundry sand, cements, plastic pellets

Chip or pellet like:

Frozen potato chips, beans, peanuts, sweets and candy, animal / pet food
Wood shavings, chalk, steering chips, styrofoams, charcoals

BENEFITS

- Dual insulation reduces temperature & humidity damage to PCB board
- No calibration required, easy use, sturdy and durable
- Rounded design prevents medium build up on probe
- Operates well under high temperature, humid and moist conditions
- High vibration force (also helps shake off build up)
- Fine powers can be detected.

Structure & Dimension

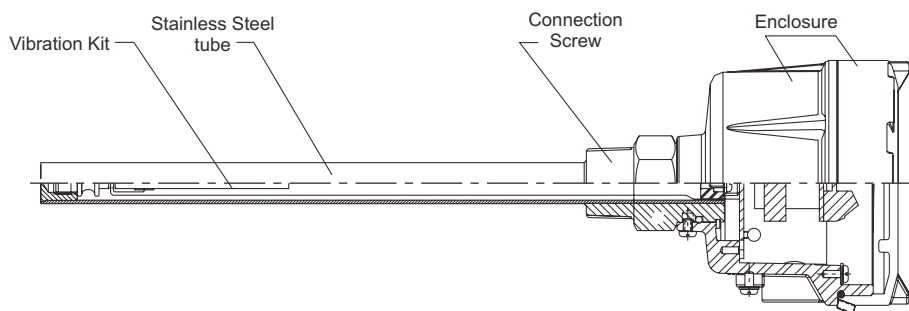

SPECIFICATIONS (Multi-Functional)

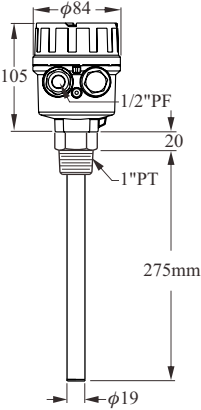
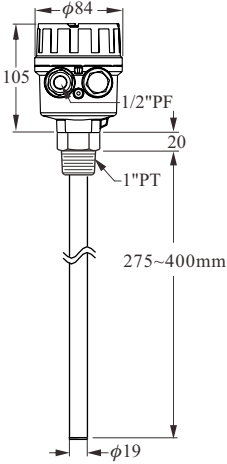
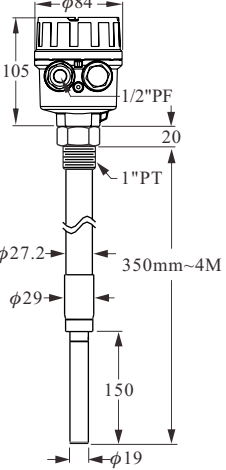
Dimensions (Unit:mm)			
Order No.	SC3100 【Standard Model】	SC3110 【Probe Extension Model】	SC3120 【Ultra Extension Model】
Level Sensor Housing	Aluminum / IP65		
Probe Material	SUS 304 / 316		
Mounting	1"PT		
Conduit	1/2"NPT × 2		
Max. Vertical load on rod.	177in.Lbs(20Nm)		
Operating Pressure.	-1~150PSI (10BAR)		
Power Supply	20~250, 50/60Hz Vac/ Vdc		
Power Consumption	15VA (Max.)		
Operating Temp. In Ambient Air	-40°C~60°C		
Operating Temp. In Bin	-40°C~80°C		
Signal Output	Relay, SPDT, 5A/250Vac, PNP/NPN(MOSFET) 400mA/60 Vac/ Vdc		
Min. material density sensed	Solid: ≥0.32g/cm ³		
Time Delay	0.6~1 Second / Operate; 2~5 Seconds / Reset		
Vibrating Frequency.	395~405HZ		
Selectable Fail-safe	Hi./ Lo.		
Selectable Sensitivity	Hi./ Mid. / Lo.		

SPECIFICATIONS (Multi-Functional)

Dimensions (Unit:mm)			
Order No.	SC3300 【Cable Extension Model】	SC3500 【Corrosion Proof Model】	SC2510 【Corrosion Proof & Extension Model】
Level Sensor Housing	Aluminum / IP65		
Probe Construction	SUS 304 / 316	SUS 304/316 Coating TEFLON	SUS 304/316 Coating TEFLON
Mounting	1"PT	Flange 1"(min.)	Flange 1"(min.)
Conduit	1/2"PF × 2		
Max. Vertical load on rod.	177in.Lbs(20Nm)		
Operating Pressure.	-1~150PSI (10BAR)	-1~150PSI (10BAR)	-1~150PSI (10BAR)
Power Supply	20~250, 50/60Hz Vac/ Vdc		
Power Consumption	15VA (Max.)		
Operating Temp. In Ambient Air	-40°C~60°C		
Operating Temp. In Bin	-40°C~80°C		
Signal Output	Relay, SPDT, 5A/250Vac, PNP/NPN(MOSFET) 400mA/60 Vac/ Vdc		
Min. material density sensed	Solid: ≥0.32g/cm ³		
Time Delay	0.6~1 Second / Operate; 2~5 Seconds / Reset		
Vibrating Frequency.	395~405HZ		
Selectable Fail-safe	Hi./ Lo.		
Selectable Sensitivity	Hi./ Mid. / Lo.		

SPECIFICATIONS

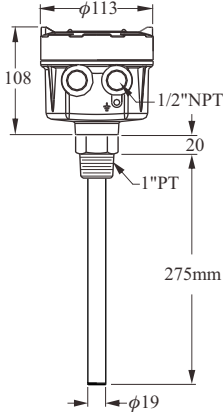
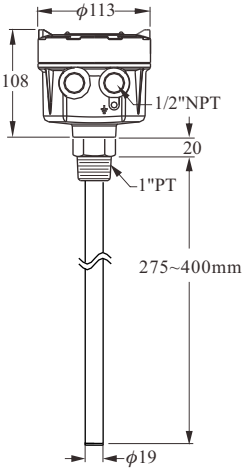
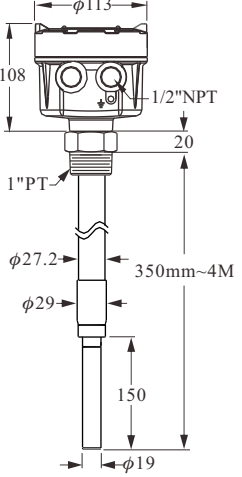
Dimensions (Unit:mm)			
Order No.	SC2100 【Standard Model】	SC2110 【Probe Extension Model】	SC2120 【Ultra Extension Model】
Level Sensor Housing	Aluminum / IP65		
Probe Construction	SUS 304 / 316		
Mounting	1"PT		
Conduit	1/2"NPT × 2		
Max. Vertical load on rod.	177in.Lbs(20Nm)		
Operating Pressure.	-1~150PSI (10BAR)		
Power Supply	20~250, 50/60Hz Vac/ Vdc		
Power Consumption	15VA (Max.)		
Operating Temp. In Ambient Air	-40°C~60°C		
Operating Temp. In Bin	-40°C~80°C		
Signal Output	Relay, SPDT, 5A/250Vac, PNP/NPN(MOSFET)400mA/60 Vac/ Vdc		
Min. material density sensed	Solid: ≥0.32g/cm ³		
Time Delay	0.6~1 Second / Operate; 2~5 Seconds / Reset		
Remote-test	Yes		
Vibrating Frequency.	395~405HZ		
Selectable Fail-safe	Hi./ Lo.		
Selectable Sensitivity	Hi./ Mid. / Lo.		

SPECIFICATIONS

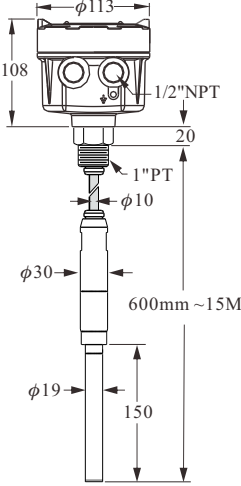
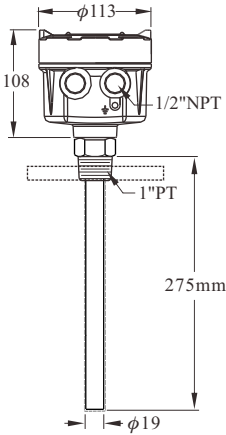
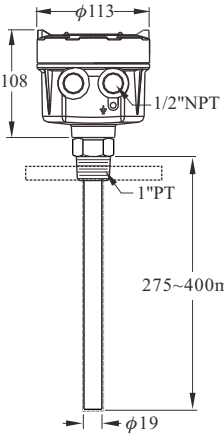
Dimensions (Unit:mm)			
Order No.	Sc2300 【Cable Extension Model】	SC2500 【Corrosion-Proof】	SC2510 【Corrosion-Proof & Extension Typ】
Level Sensor Housing	Aluminum / IP65		
Probe Construction	SUS 304 / 316	SUS 304/316 Coating TEFLON	SUS 304/316 Coating TEFLON
Mounting	1"PT	Flange 1"(min.)	Flange 1"(min.)
Conduit	1/2"NPT × 2		
Max. Vertical load on rod.	177in.Lbs(20Nm)		
Operating Pressure.	-1~150PSI (10BAR)	-1~150PSI (10BAR)	-1~150PSI (10BAR)
Power Supply	20~250, 50/60Hz Vac/ Vdc		
Power Consumption	15VA (Max.)		
Operating Temp. In Ambient Air	-40°C~60°C		
Operating Temp. In Bin	-40°C~80°C		
Signal Output	Relay, SPDT, 5A/250Vac, PNP/NPN(MOSFET)400mA/60 Vac/ Vdc		
Min. material density sensed	Solid: ≥0.32g/cm ³		
Time Delay	0.6~1 Second / Operate; 2~5 Seconds / Reset		
Remote-test	Yes		
Vibrating Frequency.	395~405HZ		
Selectable Fail-safe	Hi./ Lo.		
Selectable Sensitivity	Hi./ Mid. / Lo.		

SPECIFICATIONS

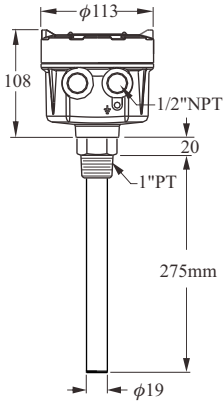
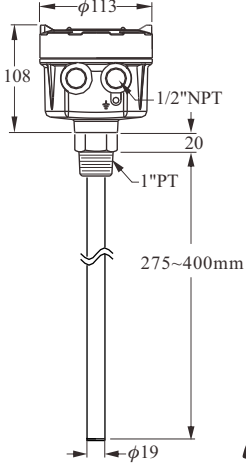
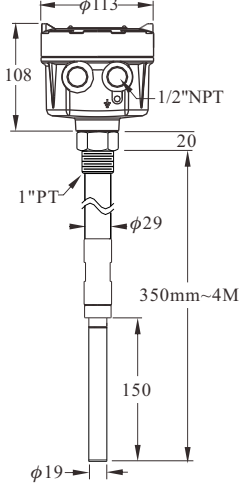
Dimensions (Unit:mm)			
Order No.	SC1700 【 Standard Type 】	SC1701 【 Probe Extension Type 】	SC1710 【 Ultra Extension Type 】
Level Sensor Housing	Aluminum		
Probe Construction	SUS 304 / 316		
Mounting	Screw: 1"PT or PF, Flange: 1"~6"JIS / DIN / ANSI		
Conduit	1/2"NPT × 2		
Max. Vertical load on rod.	177in.Lbs(20Nm)		
Operating Pressure.	-1~150PSI (10BAR)		
Power Supply	20~250Vac/dc		
Power Consumption	15W		
Operating Temp. In Ambient Air	-20°C~70°C		
Operating Temp. In Bin	-40°C~80°C		
Signal Output	Relay, SPDT , 3A/250Vac Max.		
Min. material density sensed	Solid: ≥0.32g/cm ³		
Time Delay	0.6 Second / Operate; 2~5 Seconds / Reset		
Vibrating Frequency.	395~405HZ		
Selectable Fail-safe	Hi./ Lo.		
Selectable Sensitivity	Hi./ Mid. / Lo.		

INSTALLATION

Vertical Installation (Figure 1):

1. Install the vibrating probe away from the inlet to avoid material impact or false readings.
2. Note the material flow pattern and place the vibrating probe in the appropriate position to avoid overflow.

Horizontal Installation (Figure 2)

1. Install the vibrating probe away from the inlet to avoid material impact. If this is unavoidable make use of a shield or barrier for protection.
2. Installing the vibrating probe at a 20 degree incline will optimize the results and increase sensitivity.
3. Keep the conduit facing downward to avoid moisture getting inside the housing.

Notice:

1. Users are advised to tighten the connection by using a spanner.
2. Do not bend the probe, put force on it or attempt to modify the probe length.
3. The maximum vertical pressure of the vibrating probe is 177in.Lbs (20Nm)

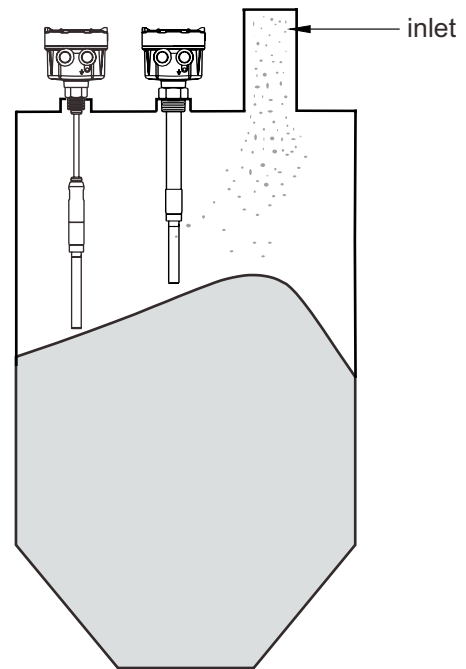

Figure 1

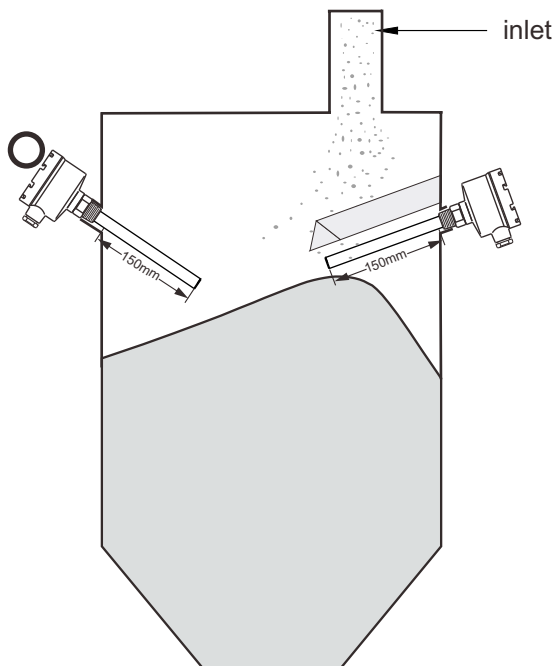

Figure 2

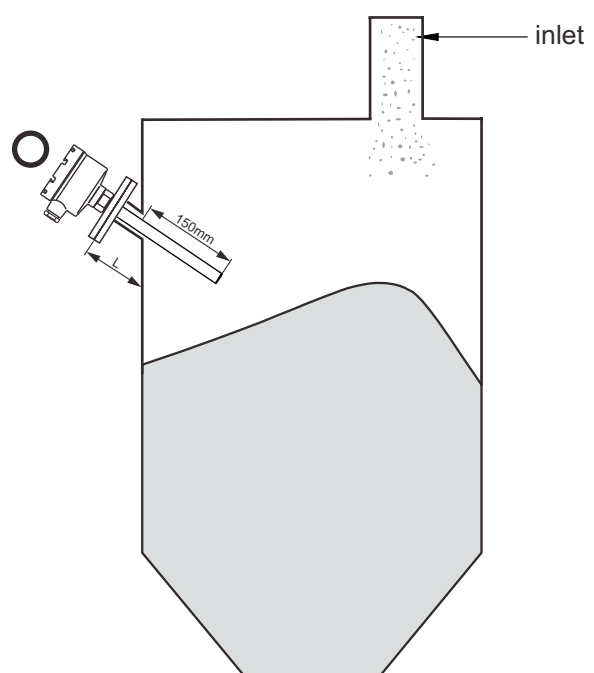
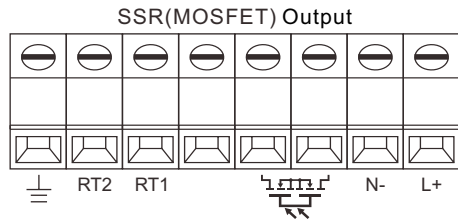
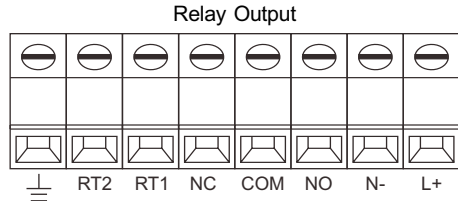
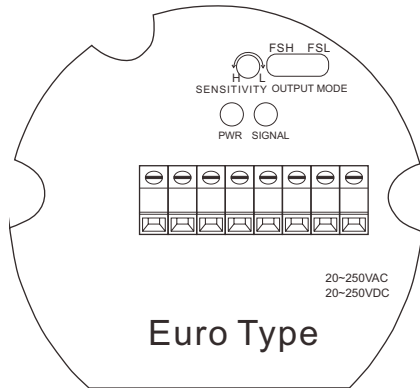

Figure 3

OPERATING INSTRUCTIONS (EURO MODEL)

SC2100X, SC2110X, SC2200X, SC2210X, SC2300X, SC2500X, SC1700X, SC1701X, SC1710X



Terminal Function

- L+, N-: Power Supply
- NC, COM, No: Relay Output
- RT1, RT2: Remote-Test
- \perp : Ground Connection
- : SSR(MOSFET) Output

Panel Function

- PWR: Power Supply (Green Light)
- SIGNAL: Output Indication (Red Light)
- FSH: Power On. The signal lamp is on and the relay is conductive. While the vibrating probe senses the material, the signal lamp is off and relay is not conductive.
- FSL: Power On. The signal lamp is off and the relay is not conductive. While the probe senses the material, the signal lamp is on and relay is conductive.
- SENSITIVITY L: Low Sensitivity
- SENSITIVITY H: High Sensitivity

Sensitivity Adjustment

1. GAIN: Located upside of PCB and not allow users to do the adjustment.
2. SENSITIVITY: Located above PCB. Three options (L.M.H) are offered for the adjustment. When switching to H position, it has the highest sensitivity. When switching to L position, it has the lowest sensitivity. The original setting is at L position and users are able to adjust the sensitivity depends on the specific gravity of material.

- H: High Sensitivity (Suitable for detecting low specific gravity material)
- M: Medium Sensitivity (Suitable for detecting medium specific gravity material)
- L : Low Sensitivity (Suitable for detecting low specific gravity material)

Fail-Safe High / Low Protection

FSH (Fail-Safe High) Protection:

Switch to FSH mode.

Normal Status: The signal lamp is on. It means that the vibrating probe does not sense the material and the relay is conductive.

Failure: When the power shuts down, the signal lamp is off. It means that the vibrating probe is voided and the relay is not conductive.

FSL (Fail-Safe Low) Protection:

Switch to FSL mode.

Normal Status: The signal lamp is on. The vibrating probe senses the material and the relay is conductive.

Failure: When the power shuts down, the signal lamp is off. The vibrating probe is voided and the relay is not conductive.

	FSL		FSH	
Level				
Contact Form	NO COM NC	NO COM NC	NO COM NC	NO COM NC
Indication				
Status	Fail	Normal	Normal	Fail

OPERATING INSTRUCTIONS (UL MODEL)

SC2100X, SC2110X, SC2200X, SC2210X, SC2300X, SC2500X, SC1700X, SC1701X, SC1710X

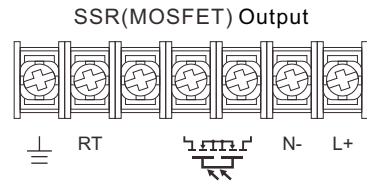
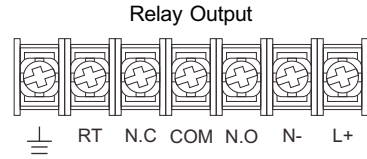
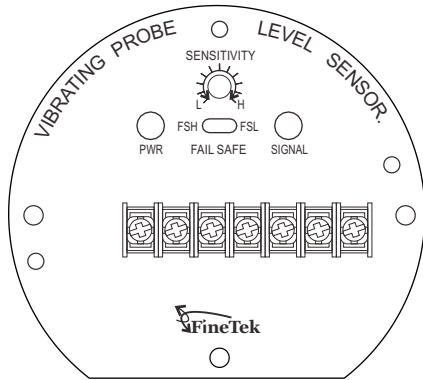

Terminal Function

- L+, N-: Power Supply
- NC, COM, No: Relay Output
- RT: Remote-Test
- ⏏ : Ground Connection
- : SSR(MOSFET) Output

Panel Function

- PWR: Power Supply (Green Light)
- SIGNAL: Output Indication (Red Light)
- FSH: Power On. The signal lamp is on and the relay is conductive. While the vibrating probe senses the material, the signal lamp is off and relay is not conductive.
- FSL: Power On. The signal lamp is off and the relay is not conductive. While the probe senses the material, the signal lamp is on and relay is conductive.
- SENSITIVITY L: Low Sensitivity
- SENSITIVITY H: High Sensitivity

Sensitivity Adjustment

1. SENSITIVITY: Located upside of PCB. When switching to H position, it has the highest sensitivity. When switching to L position, it has the lowest sensitivity. The original setting is at L position and users are able to adjust the sensitivity depends on the specific gravity of material.

- H: High Sensitivity (Suitable for detecting low specific gravity material)
- L : Low Sensitivity (Suitable for detecting low specific gravity material)

Fail-Safe High / Low Protection

FSH (Fail-Safe High) Protection:

Switch to FSH mode.

Normal Status: The signal lamp is on. It means that the vibrating probe does not sense the material and the relay is conductive.

Failure: When the power shuts down, the signal lamp is off. It means that the vibrating probe is voided and the relay is not conductive.

FSL (Fail-Safe Low) Protection:

Switch to FSL mode.

Normal Status: The signal lamp is on. The vibrating probe senses the material and the relay is conductive.

Failure: When the power shuts down, the signal lamp is off. The vibrating probe is voided and the relay is not conductive.

Level	FSL		FSH	
Contact Form	NO COM NC	NO COM NC	NO COM NC	NO COM NC
Indication				
Status	Fail	Normal	Normal	Fail

OPERATING INSTRUCTIONS (MULTI-FUNCTIONAL MODEL)

SC3100X, SC3110X, SC3120X, SC3300X, SC3500X

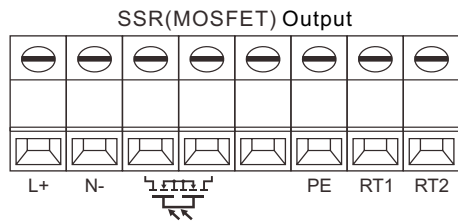
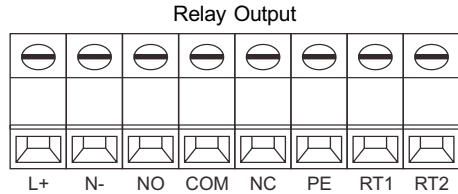
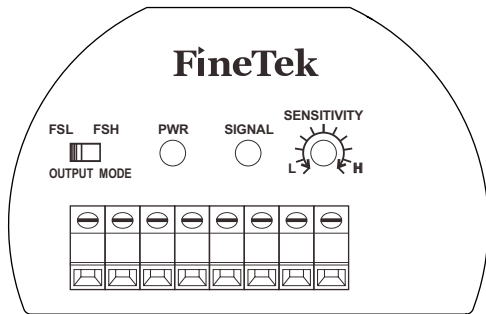

Terminal Function

- L+, N-: Power Supply
- NC, COM, No: Relay Output
- RT1, RT2: Remote-Test
- \perp : Ground Connection
- \perp : SSR(MOSFET) Output

Panel Functions

- PWR: Power Supply (Green Light)
- SIGNAL: Output Indication (Red Light)
- FSH: Power On: The signal light is on (relay is conductive). When material/solution is detected, the signal light turns off (relay is not conductive)
- FSL: Power On: The signal light turns off (relay is not conductive). When material, solution is detected, the signal light is on (relay is conductive).
- SENSITIVITY L: Low Sensitivity; H: High Sensitivity

Sensitivity Adjustment

Low, Medium and High options are available. Use the sensitivity to adjust for differing material specific gravities.

- Low specific gravity materials require higher sensitivity
- Higher specific gravity materials require lower sensitivity

GAIN: Allows for magnifying the sensitivity. The default factory setting should be sufficient for general use.

Fail-Safe

FSH (Fail-Safe High) Protection:

Switch to FSH mode.

Normal Status: The signal lamp is on. It means that the vibrating probe does not sense the material and the relay is conductive.

Failure: When the power shuts down, the signal lamp is off. It means that the vibrating probe is voided and the relay is not conductive.

FSL (Fail-Safe Low) Protection:

Switch to FSL mode.

Normal Status: The signal lamp is on. The vibrating probe senses the material and the relay is conductive.

Failure: When the power shuts down, the signal lamp is off. The vibrating probe is voided and the relay is not conductive.

Level	FSL		FSH	
Contact Form	NO COM NC	NO COM NC	NO COM NC	NO COM NC
Indication	○	☀	☀	○
Status	Fail	Normal	Normal	Fail

HOW TO ORDER

SC () ()

ORDER NO.

- Multi-Functional Models
- 3100: Standard
- 3110: Extension
- 3120: Ultra Extension
- 3300: Cable Extension
- 3500: Corrosion Proof
- Multi-Functional Models
- 2100: Standard Model
- 2110: Extension Model
- 2120: Vibrating Probe Ultra Extension Model
- 2300: Cable Extension Model
- 2500: Corrosion Proof Model
- Explosion Proof models
- 1700: Standard
- 1701: Extension
- 1710: Ultra Extension

POWER & OUTPUT MODULE

- 20~250Vac/ Vdc, 50/60Hz
- A: Relay O/P (Barrier terminal block-limited to the 17's and 21's series)
- B: Transistor PNP/NPN (Barrier terminal block-limited to the 17's and 21's series)
- R: Relay O/P (Green terminal)-EuroType
- N: Transistor PNP/NPN-EuroType

MATERIAL

- 0: SUS304 6: SUS316 P: PTFE

CONNECTION

Dimension	Specification
D---1"(25A)	M---5kg/cm ² Y---PN 25
3---1-1/4"(32A)	N---10kg/cm ² Z---PN 40
E---1-1/2"(40A)	O---150 Lbs S---others
F---2"(50A)	P---300 Lbs 9---Sanitary
G---2-1/2"(65A)	Q---PT
H---3"(80A)	R---PF(G)
I---4"(100A)	T---BSP
J---5"(125A)	U---NPT
K---6"(150A)	W---PN 10
S---others	X---PN 16

LENGTH (L) (UNIT: cm)

- 0500:** below 500mm
- 1000:** 501~1000mm
- 1500:** 1001~1500mm ※ 500mm per Unit
- ⋮ ※ The letter A depicts lengths longer than 10m: A150 =15m, A200 = 20m

CHECK – before placing order

1. Check the voltage.
2. Check the mounting positions.
3. Check the material specific gravity (S.G.) value.
4. Check whether any bridge block or vibrating motors are attached to the silo wall.

Length tolerance/margin of error : 65mm
 Characteristics, specifications and dimensions are subject to change
 Please contact your nearest distributor for further information.

EXAMPLES-OF-TANK-MOUNTING

- [FC/FD] Mini Float/Magnetic Float Level Switch
- [FG] Magnetic Float Level Transmitter
- [FF] Side Mounting Float Switch
- [FA/FB] Cable Float Level Switch
- [SP] Thermal Dispersion Flow Switch
- [SF] Paddle Flow Switch
- [SD] Optical Level Switch
- [SE] Rotary Paddle Level Switch
- [SA] Capacitance Level Switch
- [EC] Pressure Level Transmitter
- [LR] Loop Power Indicator
- [SC] Vibrating Probe Level Switch
- [SC] Tuning Fork Level Switch
- [EB] R F-Capacitance Level Transmitter
- [SB] R F-Capacitance / Admittance Level Switch
- [EG] Magnetostrictive Level Transmitter
- [EF] B y-Pass Level Transmitter
- [MEF] Mini By-Pass Level Transmitter
- [EA] U ltrasonic Level Transmitter
- [JFR] FMCW Radar Level Transmitter
- [EE] Electromechanical Level Measuring System
- [ED] Speed Monitor
- [SRT/SRS] Conveyer Belt Misalignment Switch &
S afety Cable Pull Switch
- [PB/PM] Microprocessor Based Bargraphic Display Scaling Meter
- [BRD/AE] Valve and Controller for Dust Collector System
- [BAS/BAH/BVP] Air Hammer
- [BVK/BVR/BVT] Pneumatic Vibrator

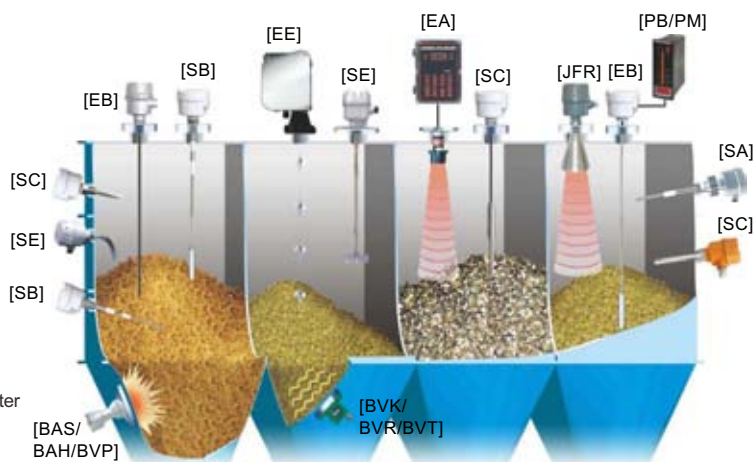
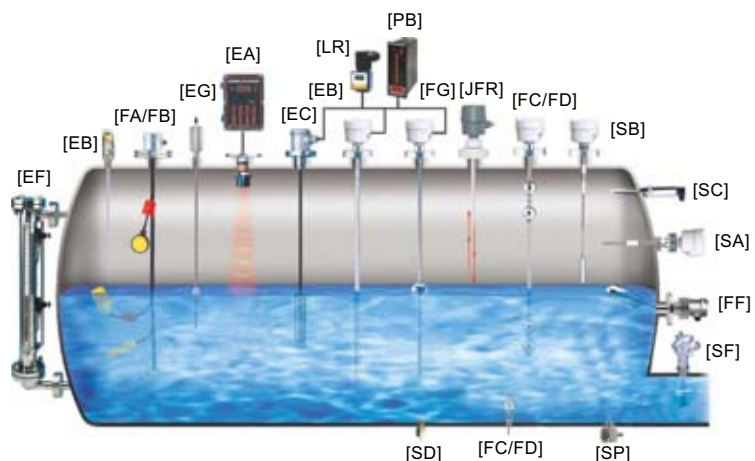

FineTek Co., Ltd.

No.16, Tzuchiang St., Tucheng Industrial Park, New Taipei City 23678, Taiwan.
 TEL: 886 2 2269 6789 FAX: 886 2 2268 6682
 Email: info@fine-tek.com http://www.fine-tek.com

Taichung Branch TEL: 886 4 2465 2820 FAX: 886 4 2463 9926
Tainan Branch TEL: 886 6 289 0635 FAX: 886 6 289 4073
Kaohsiung Branch TEL: 886 7 333 6968 FAX: 886 7 536 8758

Fine automation (ShangHai) Co., Ltd.

No.451 DuHui Rd, MinHang District, Shanghai, China 201109
 TEL: 86 21 6490 7260 FAX: 86 21 6490 7276
 Email: info.sh@fine-tek.com

FineTek Pte Ltd.

No. 11 Kaki Bukit Road 1,#04-01 Eunos Technolink 415939, Singapore
 TEL: 65 6452 6340 FAX: 65 6734 1878
 Email: info.sg@fine-tek.com

FineTek GmbH

Frankfurter Str. 62, OG D-65428 Ruesselsehim, Germany
 TEL: 49 6142 17608 0 FAX: 49 6142 17608 20
 Email: info@fine-tek.de

Aplus Finetek Sensor inc.

355 S. Lemon Ave, Suite D, Walnut, CA 91789
 TEL: 1 909 598 2488 FAX: 1 909 598 3188
 Email: peter.wu@aplusfine.com



Distributor: