

## INTRODUCTION

The By-Pass Level Indicator is installed outside of a vessel or tank. The liquid level in the tank can easily be observed from the change of the flag color. Optional devices of magnetic switch and level transducer can be added for electrical signal output and level transmitting.

## PRINCIPLE

Fine-Tek's By-Pass indicator utilizes hydrostatic principle to show the liquid level in the tank. A float with a magnet inside rises and drops according to the liquid level change. Magnetic flags will flip as float passes through to indicate liquid level based on magnetic attraction method.

## APPLICATIONS AND FEATURES

- Applicable in environment with high temp., high pressure, strong acid, strong alkaline and hazardous locations. The structure is simple but durable and reliable. It is also available with various options for upgrade.
- A level transducer or magnetic switch can be installed and adjusted during operation.
- It is not operated by electricity thus it will not be affected by power failure.
- Multiple applications for textile dyeing, sewage water processing, power generating, boiler and petrochemical industries.

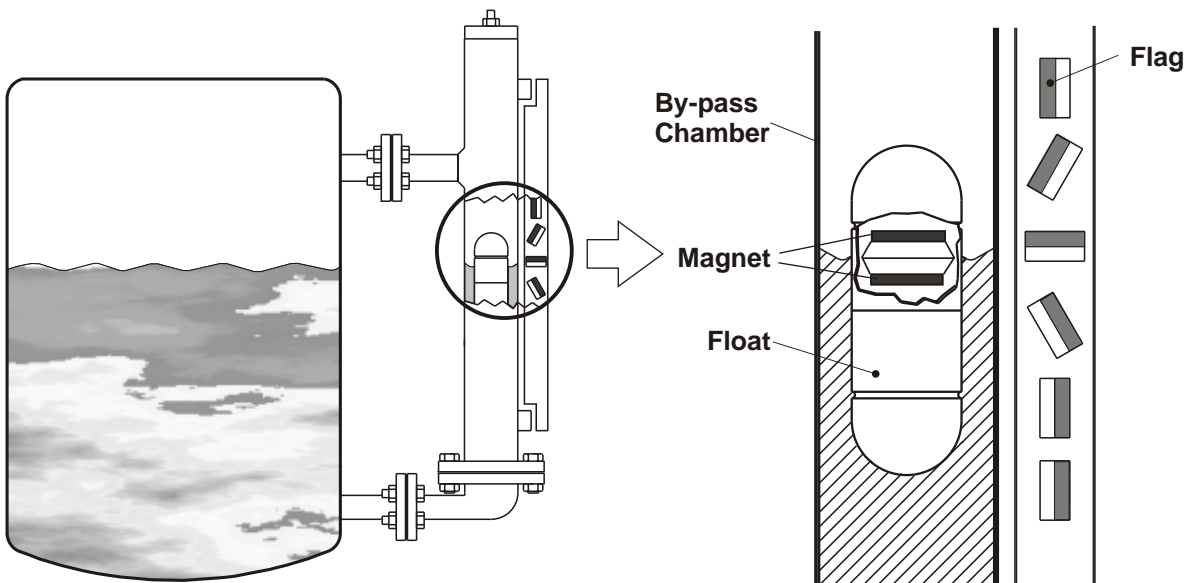

# PRODUCT WITH PATENT RECOMMENDATION

## 1.) Magnetic Switch

- \* The plastic miniature magnetic switch is anti-corrosive and with IP67 rating. It is the smallest magnetic switch in the current market.
- \* The magnetic switch is easy to set up and has real time adjustment.

## 2.) Innovative Design For Bottom End Flange and the Connecting Flange

- \* The lower center duct is at the bottom end of the chamber. When the liquid drains in the tank, there will be no residue in the chamber unit.
- \* This is suitable for production that requires frequent liquid change and mixture is not allowed during the process.

## 3.) Removable Duct and Connecting Flange

- \* The flange setting is close to the two ends of the chamber, therefore the "C-C" distance is maximized.
- \* It is strengthened in the structure by a large phase weld.
- \* During the installation, adjust the flange to the fitting mounting holes.

TYPE: EF-□-B1L

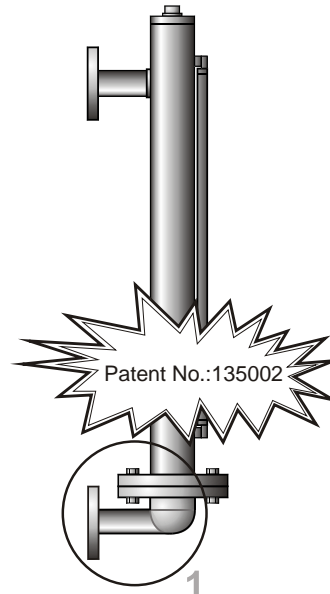

Innovative Bottom End Flange and the Connecting Flange

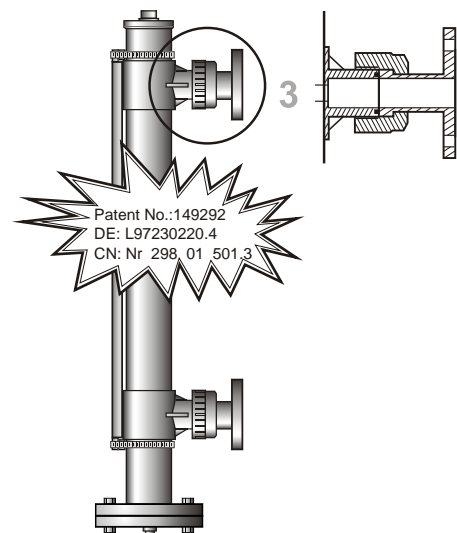
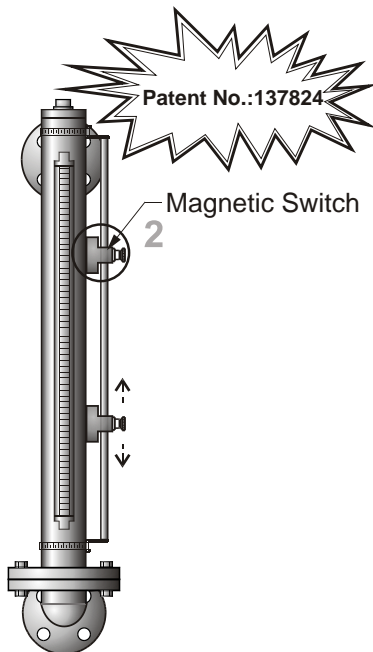

## Plastic Standard Type

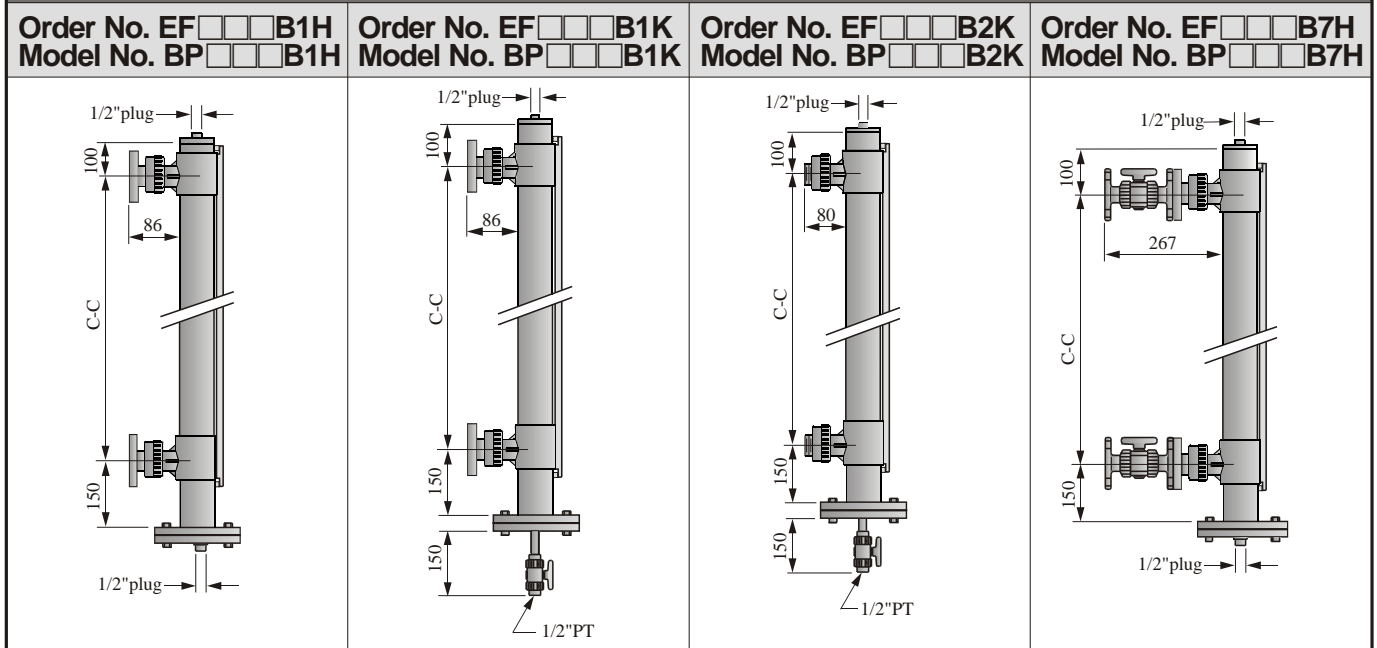

### SPECIFICATIONS:

Order No. Description	EF□□□B1H	EF□□□B1K	EF□□□B2K	EF□□□B7H
<b>Top End</b>	Flat top with 1/2"PT plug			
<b>Bottom End</b>	Dual flange with 1/2"PT plug	Dual flange with 1/2"PT drain valve		Dual flange with 1/2"PT plug
<b>Connecting</b>	3/4" x10kg/cm <sup>2</sup> (Flange)		3/4" or 1"PT (Screw)	3/4" x10kg/cm <sup>2</sup> (Ball Valve)
<b>C-C Distance</b>	Min. 150mm; Max. 3800mm			
<b>Operation Pressure</b>	5kg/cm <sup>2</sup>			
<b>Operation Temp.</b>	PP: 80°C, PVDF: 120°C			
<b>Chamber</b>	PP: φ60.5 x 3.8t, PVDF: φ63 x 3.2t			
<b>Float Type</b>	EFB-2500 (PVDF) / 2510 (PP) (see page 9)			
<b>Material</b>	PP / PVDF			
<b>Flag Indicator</b>	EFB-0750 (140°C) (see page 11)			
<b>Ruler</b>	Option (see page 14)			

Order No. EF□□□C1H  
 Model No. BP□□□C1H

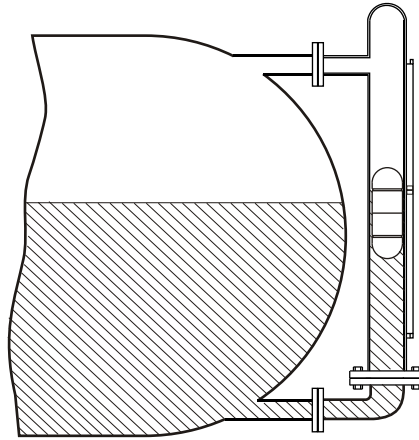
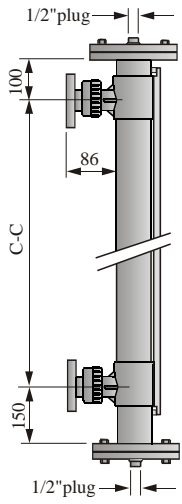

**STYLE A1L (ANGLE PIPE)**

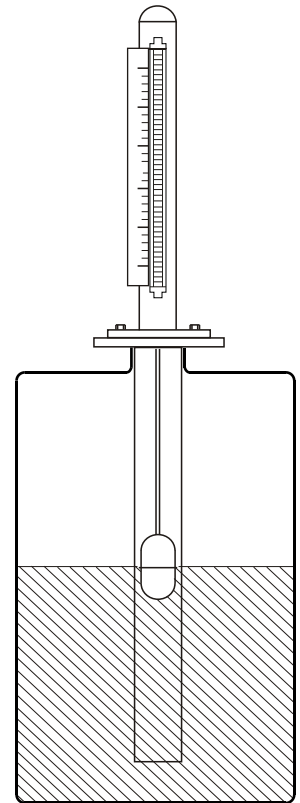

**STYLE A5M (TANK TOP)**

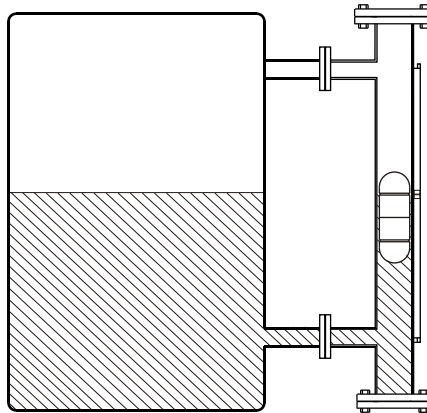

**STYLE CIH (SIDE FLANGE)**

**EF□□□C1H**

Dual flange  
with 1/2"PT plug

Dual flange  
with 1/2"PT plug

3/4" x10kg/cm<sup>2</sup> (Flange)

Min. 150mm;  
Max. 3800mm

5kg/cm<sup>2</sup>

PP: 80°C, PVDF: 120°C

PP: φ60.5 x 3.8t,  
PVDF: φ63 x 3.2t

EFB-250(PVDF) / 2510(PP)  
(see page 9)

PP / PVDF

EFB-0750 (140°C)  
(see page 11)

Option (see page 14)

## Metal Standard Type

**Order No. EF**    **A1H**   
 **Order No. EF**    **A5M**   
 **Order No. EF**    **B1H**   
 **Order No. EF**    **B1K**  
**Model No. BP**    **A1H**   
 **Model No. BP**    **A5M**   
 **Model No. BP**    **B1H**   
 **Model No. BP**    **B1K**

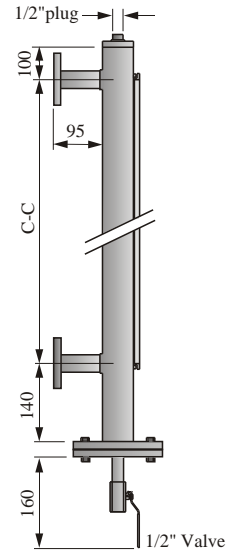
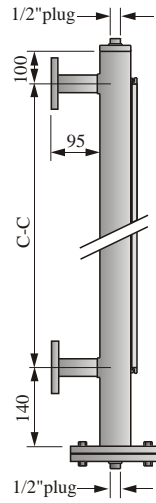
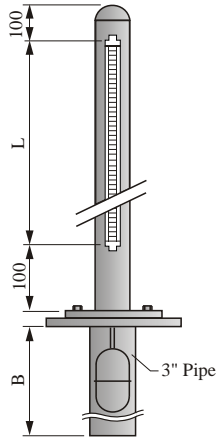
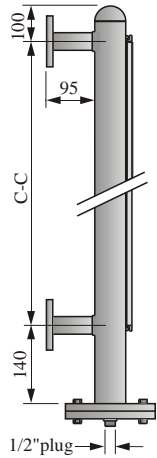

### SPECIFICATIONS:

Order No. Description	EF <input type="text"/> <input type="text"/> <input type="text"/> <b>A1H</b>	EF <input type="text"/> <input type="text"/> <input type="text"/> <b>A5M</b>	EF <input type="text"/> <input type="text"/> <input type="text"/> <b>B1H</b>	EF <input type="text"/> <input type="text"/> <input type="text"/> <b>B1K</b>
<b>Top End</b>	Cap		Flat top with 1/2"PT plug	
<b>Bottom End</b>	Dual flange with 1/2"PT plug	Dual flange with 3" shield pipe	Dual flange with 1/2"PT plug	Dual flange with 1/2" drain valve
<b>Bottom Flange</b>	1-1/2" x 5kg/cm <sup>2</sup>	3-1/2" x 5kg/cm <sup>2</sup>	1-1/2" x 5kg/cm <sup>2</sup>	
<b>Connecting</b>	3/4" x 10kg/cm <sup>2</sup> (Flange)	3" (Hole)	3/4" x 10kg/cm <sup>2</sup> (Flange)	
<b>C-C Distance Flag Display Length(L)</b>	Min. 150mm; Max. 5,800mm	Min. 150mm; Max. 2,000mm	Min. 150mm; Max. 5.800mm	
<b>Operation Pressure</b>	25kg/cm <sup>2</sup> (Max. 50kg/cm <sup>2</sup> )			20kg/cm <sup>2</sup>
<b>Operation Temp.</b>	SUS304: 140°C, 200°C, 400°C SUS316: 140°C, 200°C, 400°C			SUS304: 140°C, 200°C, 350°C SUS316: 140°C, 200°C, 350°C
<b>Chamber</b>	φ60.5 x 2.8t			
<b>Float Type</b>	EFB-2580 (see page 10)			
<b>Material</b>	SUS304 / SUS316			
<b>Flag Indicator</b>	EFB-0750 (140°C), EFB-0700 (200°C), EFB-0740 (400°C) (see page 11)			
<b>Ruler</b>	Option (see page 14)			

Metal Standard Type			Jacket Type
Order No. EF□□□B2K Model No. BP□□□B2K	Order No. EF□□□B7H Model No. BP□□□B7H	Order No. EF□□□C1H Model No. BP□□□C1H	Order No. EF□□□C8H Model No. BP□□□C8H

## SPECIFICATIONS:

Order No.	EF□□□B2K	EF□□□B7H	EF□□□C1H	EF□□□C8H
<b>Description</b>				
<b>Top End</b>	Flat top with 1/2"PT plug		Dual flange with 1/2"PT plug	
<b>Bottom End</b>	Dual flange with 1/2" drain valve	Dual flange with 1/2"PT plug		
<b>Bottom Flange</b>	1-1/2" x 5kg/cm <sup>2</sup>			2-1/2" x 5kg/cm <sup>2</sup>
<b>Connecting</b>	3/4"PT or 1"PT (Screw)	3/4" x 10kg/cm <sup>2</sup> (Ball Valve)	3/4" x 10kg/cm <sup>2</sup> (Flange)	1-1/4" x 10kg/cm <sup>2</sup> (Flange)
<b>C-C Distance</b>	Min. 150mm; Max. 5,800mm			
<b>Operation Pressure</b>	20kg/cm <sup>2</sup>	10kg/cm <sup>2</sup>	25kg/cm <sup>2</sup> (Max. 50kg/cm <sup>2</sup> )	
<b>Operation Temp.</b>	SUS304: 140°C, 200°C, 350°C SUS316: 140°C, 200°C, 350°C		SUS304: 140°C, 200°C, 400°C SUS316: 140°C, 200°C, 400°C	
<b>Chamber</b>	φ60.5 x 2.8t			Jacket φ76 x 3.0t 1/2"PT plug
<b>Float Type</b>	EFB-2580 (see page 10)			
<b>Material</b>	SUS304 / SUS316			
<b>Flag Indicator</b>	EFB-0750 (140°C), EFB-0700 (200°C), EFB-0740 (400°C) (see page 11)			
<b>Ruler</b>	Option (see page 14)			

Metal Standard Type	Antiseptic Type	Removable Insulation
Order No. EF□□□B1L Model No. BP□□□B1L	Order No. EF□□□C1H Model No. BP□□□C1H	Order No. EF□□□C1H Model No. BP□□□C1H
<p><b>EF□□□B1L</b></p>	<p><b>EF□□□C1H</b></p>	<p><b>EF□□□C1H</b></p>

### SPECIFICATIONS:

Order No. Description	EF□□□B1L	EF□A/B□C1H	EF□□□C1H
<b>Top End</b>	Flat top with 1/2"PT plug	Dual flange	Dual flange with 1/2"PT plug
<b>Bottom End</b>	Dual flange with Angle pipe	Dual flange	Dual flange with 1/2"PT plug
<b>Connecting</b>	3/4" x10kg/cm <sup>2</sup> (Flange)		
<b>C-C Distance</b>	Min. 150mm; Max. 5800mm	Min. 150mm; Max. 3800mm	Min. 150mm; Max. 5800mm
<b>Operation Pressure</b>	25kg/cm <sup>2</sup> (Max. 50kg/cm <sup>2</sup> )		
<b>Operation Temp.</b>	SUS304: 140°C, 200°C SUS316: 140°C, 200°C	PP: 80°C PTFE:120°C	SUS304: 140°C, 200°C, 400°C SUS316: 140°C, 200°C, 400°C
<b>Chamber</b>	φ60.5 x 2.8t	φ65 x 2t Coating PP or PTFE	φ60.5 x 2.8t Removable Insulation
<b>Float Type</b>	EFB-2580 (see page 10)	EFB-2580 (see page 10)+Coating	EFB-2580 (see page 10)
<b>Material</b>	SUS304 / SUS316		
<b>Flag Indicator</b>	EFB-0750 (140°C), EFB-0700 (200°C), EFB-0740 (400°C) (see page 11)		
<b>Ruler</b>	Option (see page 14)		

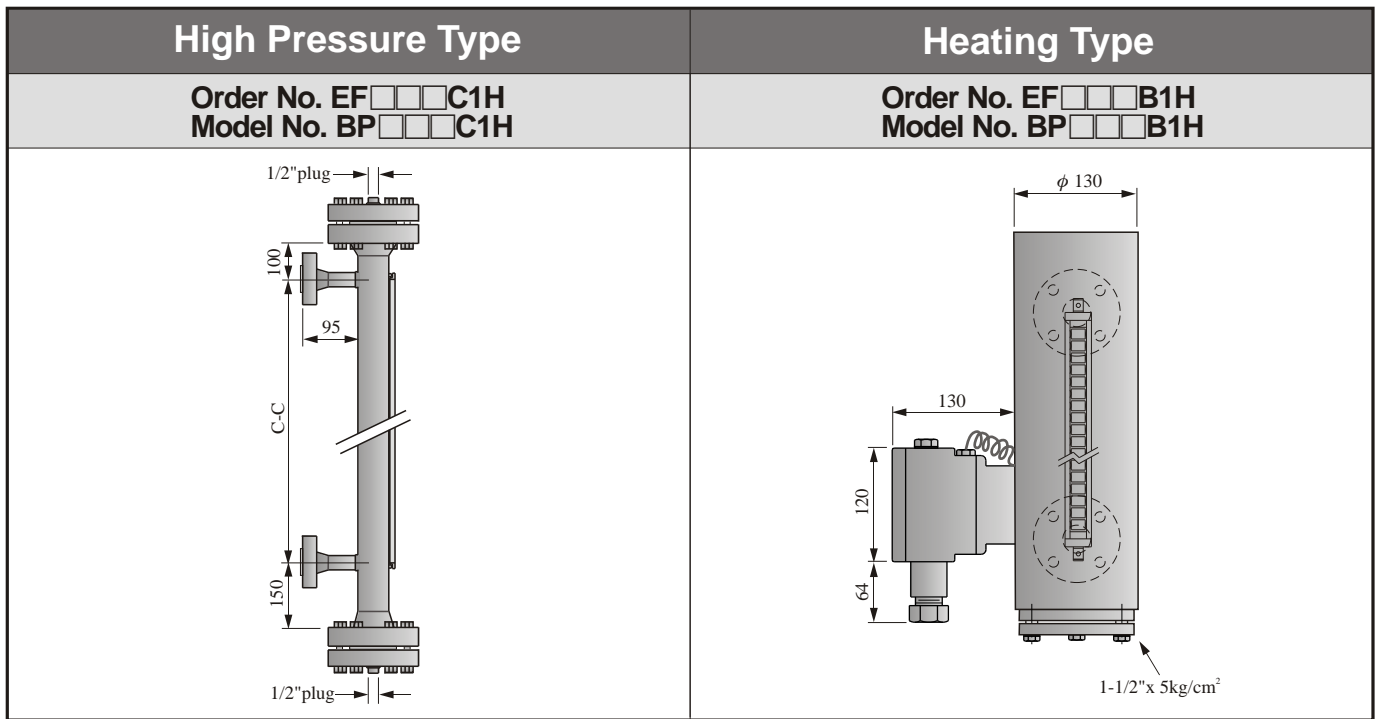

### SPECIFICATIONS:

Order No.	EF <input type="text"/> <input type="text"/> <input type="text"/> <b>C1H</b>	EF <input type="text"/> <input type="text"/> <input type="text"/> <b>B1H</b>
<b>Description</b>		
<b>Top End</b>	Dual flange with 1/2"PT plug	Flat top with 1/2"PT plug
<b>Bottom End</b>	Dual flange with 1/2"PT plug	
<b>Connecting</b>	600Lb or 300Lb	3/4" x 10kg/cm <sup>2</sup> (Flange)
<b>C-C Distance</b>	Min. 150mm; Max. 5800mm	
<b>Operation Pressure</b>	100kg/cm <sup>2</sup> (300°C down)600Lb 60kg/cm <sup>2</sup> (300°C up)300Lb	20kg/cm <sup>2</sup>
<b>Operation Temp.</b>	SUS304: 140°C SUS316: 140°C	SUS304: 100°C SUS316: 100°C
<b>Chamber</b>	$\phi$ 76.3 x 5.5t	$\phi$ 65 x 3.5t $\phi$ 130 Heating type
<b>Float Type</b>	EFB-2654 (see page 10)	EFB-2580 (see page 10)
<b>Material</b>	SUS304 / SUS316	
<b>Flag Indicator</b>	EFB-0700(200°C), EFB-0740(400°C) (see page 11)	
<b>Ruler</b>	Option (see page 14)	



# PLASTIC FLOAT SPECIFICATIONS

---

## SPECIFICATIONS:

Order No.	Spec. Order No.	Operation Temp.	Max. Pressure	Dimension	S.G.	Water Immersion Line	Material	Weight
1	EFB-2500	-10~120 °C	5 kg/cm <sup>2</sup>	φ51x168	0.75	126 mm	PVDF	256 g
2	EFB-2510	-10~80 °C	5 kg/cm <sup>2</sup>	φ49x150	0.7	105 mm	PP	188 g

\*Specified S.G. is available made to order.

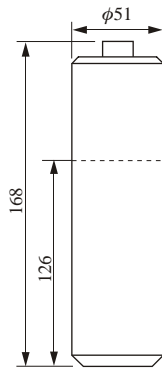

TYPE: EFB-2500 (PVDF)

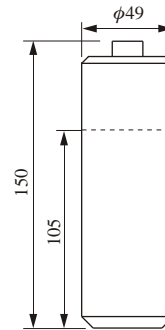

TYPE: EFB-2510 (PP)

# METAL FLOAT SPECIFICATIONS

## SPECIFICATIONS:

Order No.	Spec. Type	Operation Temp.	Max. Pressure	Dimension	S.G.	Water Immersion Line	Material	Weight
3	EFB-2540	400°C	30 kg/cm <sup>2</sup>	φ50x200	0.7	140 mm	SUS316	234 g
A	EFB-2560	400°C	30 kg/cm <sup>2</sup>	φ50x175	0.75	131 mm	SUS316	220 g
C	EFB-2580	400°C	40 kg/cm <sup>2</sup>	φ50x150	0.87	130 mm	SUS316	207 g
I	EFB-2592	200°C	60 kg/cm <sup>2</sup>	φ50x230	0.72	166 mm	SUS316	284 g
		201°C~400°C	45 kg/cm <sup>2</sup>					
K	EFB-2654	300°C	110 kg/cm <sup>2</sup>	φ61.3x394	0.8	315 mm	Titanium	910 g
		301°C~400°C	90 kg/cm <sup>2</sup>					
D	EFB-2600	400°C	40 kg/cm <sup>2</sup>	φ50x295	0.68	204 mm	SUS316	330 g
E	EFB-2620	400°C	15 kg/cm <sup>2</sup>	φ50x140	0.6	84 mm	Titanium	148 g
G	EFB-2630	400°C	20 kg/cm <sup>2</sup>	φ50x210	0.51	107 mm	Titanium	183 g

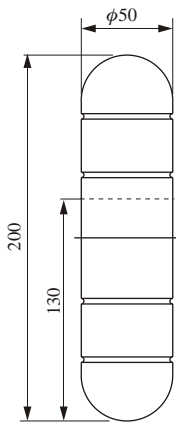

TYPE: EFB-2540

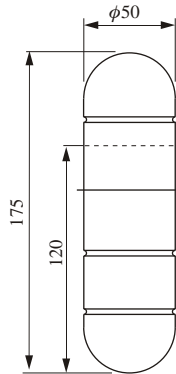

TYPE: EFB-2560

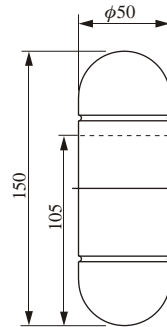

TYPE: EFB-2580

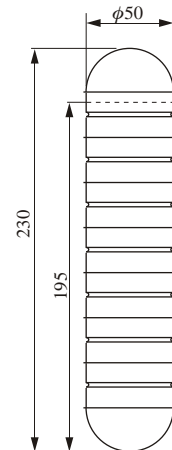

TYPE: EFB-2592

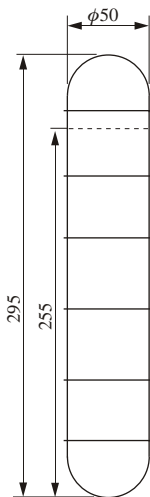

TYPE: EFB-2600

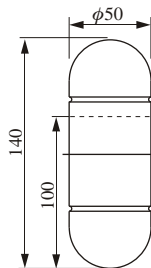

TYPE: EFB-2620

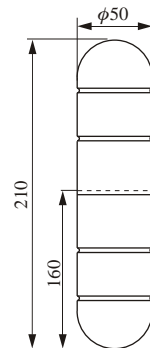

TYPE: EFB-2630

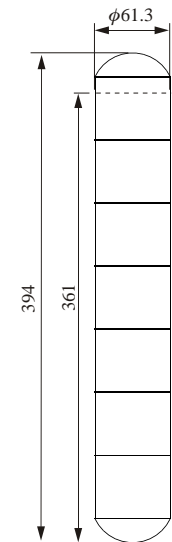

TYPE: EFB-2654

\*The dotted line is the Magnet location.

# FLAG DISPLAY

**Order No. EFB-0700**  
**Model No. BPB-0700**

1. Housing material : SUS 304
2. Flag Material : Engineering plastic
3. Flag Color : Red / White; Green / White
4. Cover Material : Engineering plastics
5. Operation Temp. : -20~200°C
6. Standard Unit : 50mm

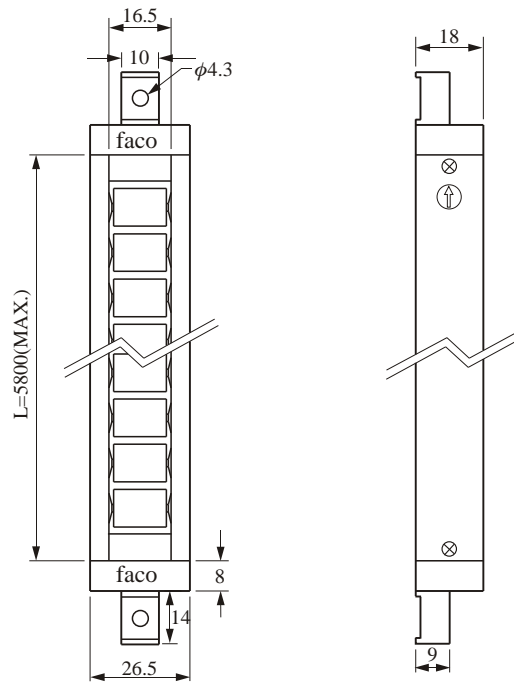

**Order No. EFB-0740**  
**Model No. BPB-0740**

1. Housing material : SUS 304
2. Flag Material : Ceramic
3. Flag Color : Red / White; Green / White
4. Cover Material : Glass
5. Operation Temp. : -20~400°C
6. Standard Unit : 50mm

**Order No. EFB-0750**  
**Model No. BPB-0750**

1. Housing material : SUS 304
2. Flag Material : Engineering plastic
3. Flag Color : Red / White; Green / White
4. Cover Material : Engineering plastics
5. Operation Temp. : -20~140°C
6. Standard Unit : 50mm

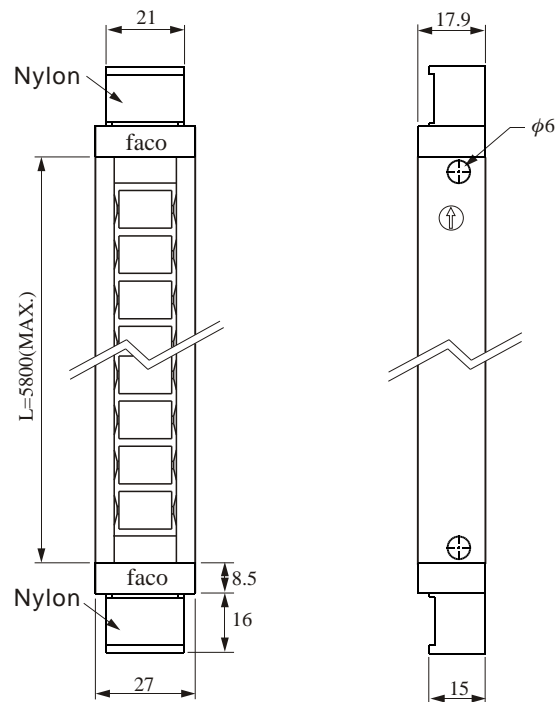

# BALL VALVE

**TYPE: LN-010**

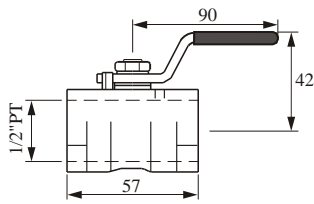

**TYPE: LN-02**

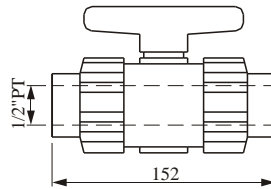

PART	LN-010	LN-021	LN-022
1 Body Material	SUS316	PP	PVDF
2 Working Temp.	150°C	80°C	120°C
3 Working Pres.	1/2"PT	1/2"PT	
4 Connection	20kg/cm <sup>2</sup>	5kg/cm <sup>2</sup>	

**TYPE: LN-□ 30**

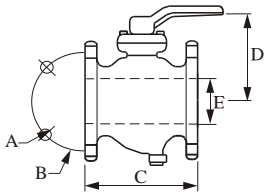

**DIMENSIONS**

SIZE CODE	3/4"	1"
A, B	ACCORDING TO JIS 10K	
C	120	130
D	90	90
E	21.8	25

PART	LN-□30
1 Body Material	SUS304
2 Working Temp.	150°C
3 Working Pres.	10kg/cm <sup>2</sup>
4 Connection	LN-□ 30 └ 2: 3/4" JIS 10K └ 3: 1" JIS 10K

**TYPE: LN-□ 4**

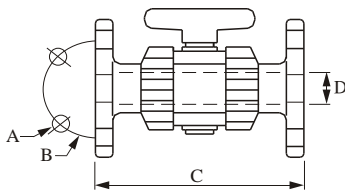

**DIMENSIONS**

SIZE CODE	3/4"	1"
A, B	ACCORDING TO JIS 10K	
C	172	187
D	18	23

PART	LN-□41	LN-□42
1 Body Material	PP	PVDF
2 Working Temp.	80°C	120°C
3 Working Pres.	5kg/cm <sup>2</sup>	
4 Connection	LN-□ 49 └ 2: 3/4" JIS 10K └ 3: 1" JIS 10K	

## High Temp. Control Valve

**TYPE: LN-□50**

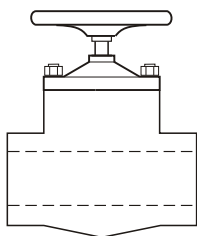

**TYPE: LN-□60**

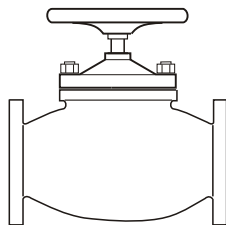

PART	LN-□50	LN-□60
1 Body Material	SUS316	SUS316
2 Working Temp.	350°C	350°C
3 Working Pres.	25kg/cm <sup>2</sup>	25kg/cm <sup>2</sup>
4 Connection	LN-□ 50 └ 2: 3/4"PT └ 3: 1"PT	LN-□ 60 └ 2: DN15 PN16 └ 3: DN20 PN16

# OPTIONS

As shown below the optional accessories can be installed on to a By-Pass Level Indicator to monitor and control the level of the liquid.

## A. Magnetic Switch (see page 15)

- 1) Economy Type : EFB-1220 series
- 2) Standard Type : EFB-1250 series
- 3) Explosion-proof Type : EFB-1300 series
- 4) Adjustable Type : EFB-1400 series

## B. Level Transducer (see page 16)

## C. Ruler (see page 14)

- 1) Stainless steel in cm : EFA-2110/2111(L Type)
- 2) Stainless steel in inch : EFA-2120
- 3) Plastic in cm : EFA-2130
- 4) Plastic in inch : EFA-2140

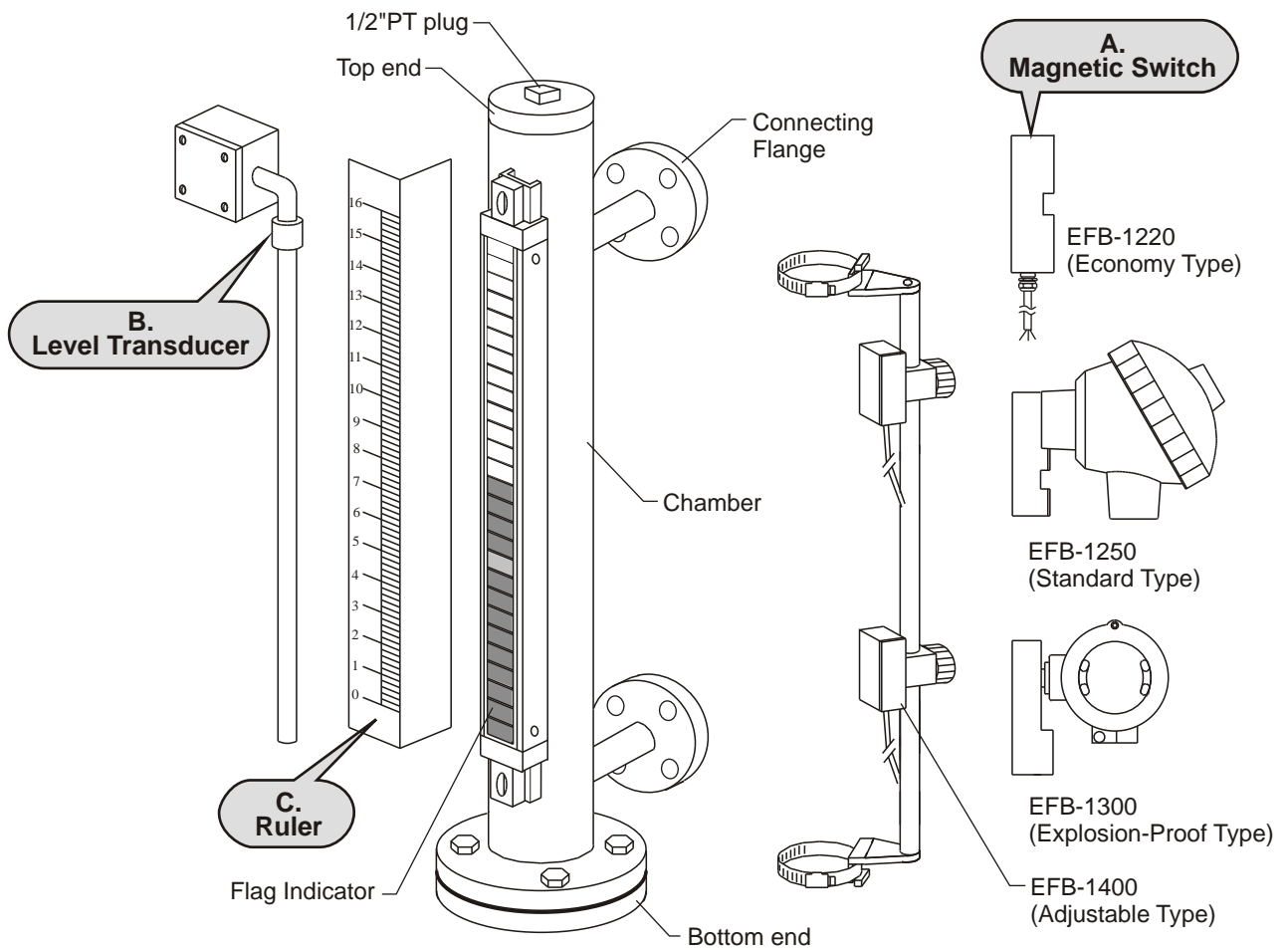

# RULER

**Model No. BPA-2111 (unit: cm L Type)**  
**Order No. EFA-2111**

**Model No. BPA-2120 (unit: inch)**  
**Order No. EFA-2120**

1. Dimension : 35(W)x1.5(T)xL
2. Material : SUS 304
3. Color : Black word
4. Operation Temp. : -20~400°C
5. Length : 5.8M (228")

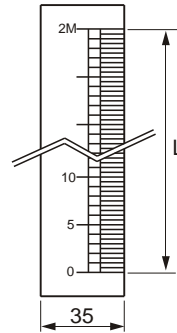

**EFA-2111**

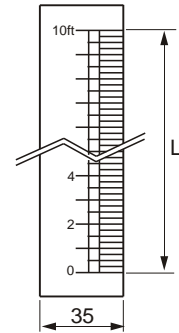

**EFA-2120**

**Model No. BPA-2130 (unit: cm)**  
**Order No. EFA-2130**

**Model No. BPA-2140 (unit: inch)**  
**Order No. EFA-2140**

1. Dimension : 26(W)x3(T)xL
2. Material : Plastic
3. Color : Red word
4. Operation Temp. : -20~80°C
5. Length : 5.8M (228")

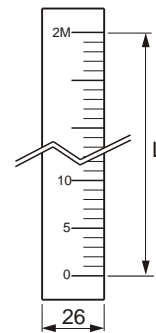

**EFA-2130**

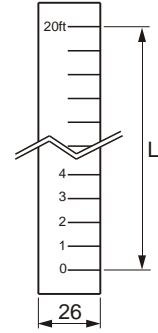

**EFA-2140**

\* Custom-made scale is available.

# MAGNETIC SWITCH

## [ ECONOMY TYPE ]

**Order No. EFB-1220/1230**

**Model No. BPB-1220/1230**

1. Contact Element : Reed Switch
2. Switch Form : EFB-1220, SPDT Hold type  
EFB-1230, SPDT Normal type
3. Contact Capacity : 1A /30W / 200Vdc /240Vac
4. Housing Material : Aluminum
5. Operation Temp. : -20~200°C
6. Protection : IP67
7. Cable Length : 1M (Silicon Cable)

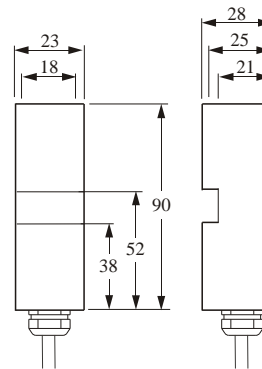

Contact wire color code :  
Black : COM  
Brown : NC  
Blue : NO  
Yellow/Green : GND

## [ STANDARD TYPE ]

**Order No. EFB-1250/1260**

**Model No. BPB-1250/1260**

1. Contact Element : Reed switch
2. Switch Form : EFB-1250, SPDT Hold type  
EFB-1260, SPDT Normal type
3. Contact Capacity : 1A /30W / 200Vdc /240Vac
4. Housing Material : Aluminum
5. Operation Temp. : -20~150°C(max. 250°C)
6. Protection : IP65

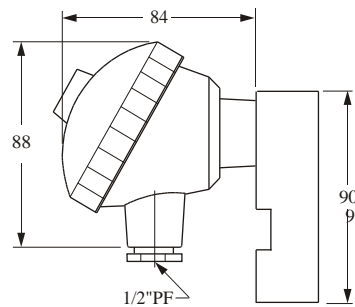

## [ ENCLOSURE EXPLOSION-PROOF TYPE ]

**Order No. EFB-1300/1310**

**Model No. BPB-1300/1310**

1. Contact Element : Reed switch
2. Switch Form : EFB-1300, SPDT Hold type  
EFB-1310, SPDT Normal type
3. Contact Capacity : 1A /30W / 200Vdc /240Vac
4. Housing Material : Aluminum
5. Operation Temp. : -20~85°C (max. 250°C)
6. Protection : Ex d IIC T6

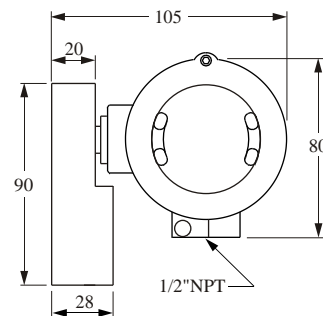

## [ ADJUSTABLE TYPE ]

**Order No. EFB-14□□**

**Model No. BPB-14□□**

1. Contact Element : Reed Switch
2. Switch Form : EFB-1400, SPST NO Hold type  
EFB-1410, SPST NO Normal type  
EFB-1420, SPDT Hold type  
EFB-1430, SPDT Normal type  
EFB-1450, SPST NO Hold type (LED display)
3. Contact Capacity : 1A /30W / 200Vdc /240Vac
4. Housing Material : PP
5. Operation Temp. : -20~140°C
6. Protection : IP67
7. Cable Length : 2M (PVC Cable)
8. Contact wire color code:  
Red: COM, White: NO (EFB-1400/ 1410 / 1450)  
Black: COM, Red: NC, White: NO (EFB-1420 / 1430)

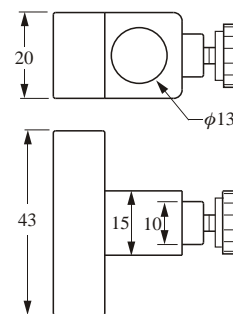

EFB-1450 Wiring

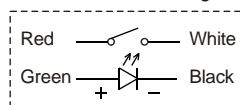

# LEVEL TRANSDUCER

## TYPE: FGCG□0

- Housing material : PC(IP65) 85(W)x80(H)x55(D)
- Tube :  $\phi 14\text{mm} / \phi 17.2$  (length over 3M)  
SUS 304 or SUS 316
- Accuracy : 6.35mm
- Output : 4~20mA two-wire
- Power : 12~36Vdc
- Measuring Range : 0.15~3M / 3~5.8M ( $\phi 17.2$ )
- Ambient Temp. : -10~80°C

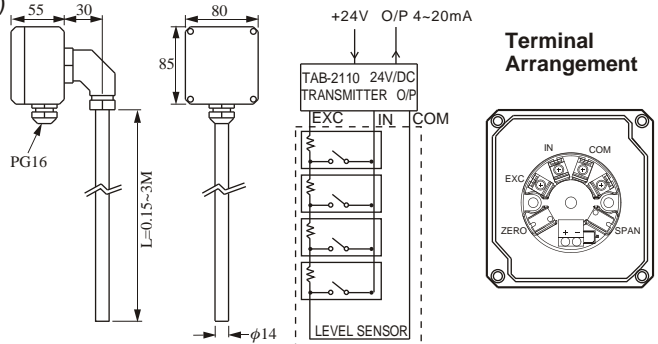

## TYPE: FGCL□0

- Housing material : Aluminum EEx d IIC T6
- Tube :  $\phi 14\text{mm} / \phi 17.2$  (length over 3M)  
SUS 304 or SUS 316
- Accuracy : 6.35mm
- Output : 4~20mA two-wire
- Power : 12~36Vdc
- Measuring Range : 0.15~3M / 3~5.8M ( $\phi 17.2$ )
- Ambient Temp. : -10~80°C

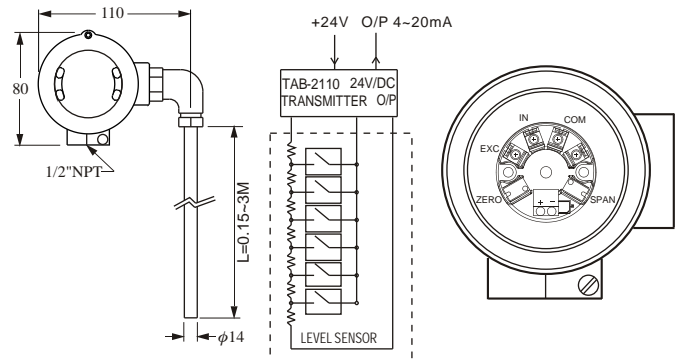

## ORDER INFORMATION

**FG A G 4 0**

### RESOLUTION

- A: 6.35mm (3-wire)
- C: 6.35mm (2-wire) with TAB-2110

### TERMINAL HOUSING

- G: PC (IP65)
- K: Aluminum (EEx d IIC T6)
- L: Aluminum (EEx d IIC T6)
- N: SUS304 or 316 (EEx d IIB T3~T6)
- X: Aluminum (IP65)

### TUBE TYPE & MATERIAL

- 4:  $\phi 14$  (SUS)
- 7:  $\phi 17.2$  (SUS)
- 8:  $\phi 20$  (PVDF)

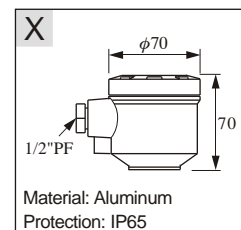
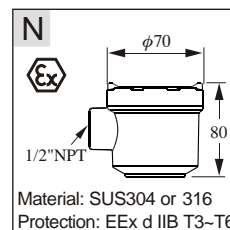
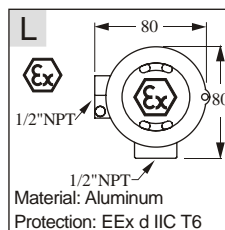
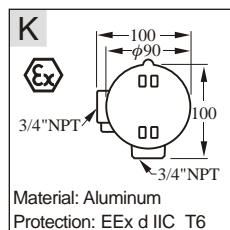
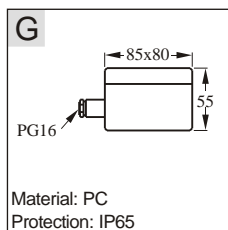



# TRANSDUCER & TRANSDUCER WIRING DIAGRAMS

## MODEL: TAB-2110 Transducer

- Power Supply : 12~36Vdc
- Output Current : Loop power 4~20mA
- Load Resistance :  $R_L(\text{Max})=50(Vs-8)$
- Operation Temperature : -40~80 °C
- Ambient Humidity : 0~80 RH
- Accuracy :  $\pm 0.1\%(25^\circ\text{C})$
- Temperature Effect : 0.01%F.S./°C
- Adjustment Range : Span Adjustment 20% FS  
Span Adjustment 5% FS

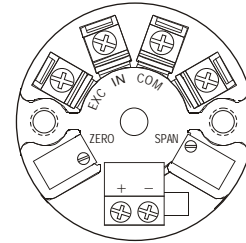

## TRANSDUCER WIRING DIAGRAMS

► Level transducer (resistance output) connected with analog meter for level monitoring.

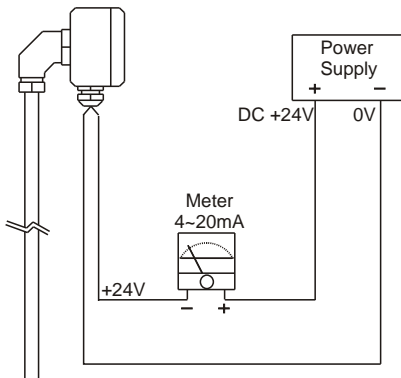

► Level transducer (4~20mA output) connected with 4~20mA analog meter for level monitoring.

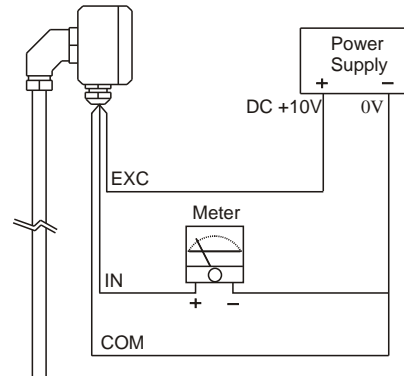

► Level transducer (4~20mA output) connected with digital meter (PB-Series) for level control.

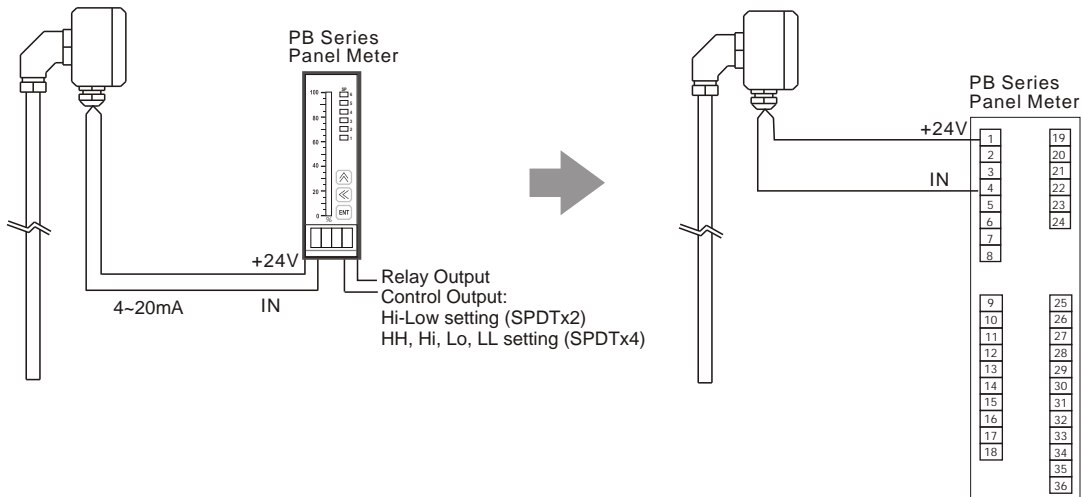

# TYPICAL ASSEMBLY

---

1. By-pass Level indicator with the standard magnetic switches (Aluminum Alloy) and liquid level transmitter. With the housing protection IP65, it is suitable for outdoor or moist environment.

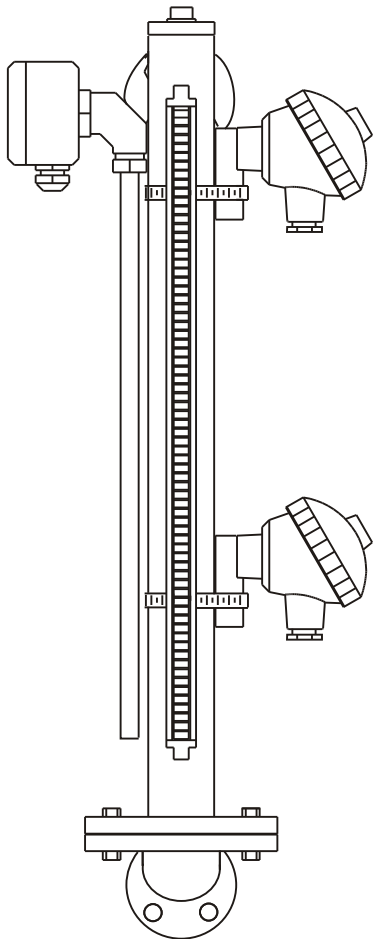

fig. 1

2. By-pass Level Indicator with explosion-proof magnetic switches. With its housing protection Ex d IIC T6, it is applicable for hazardous environments .

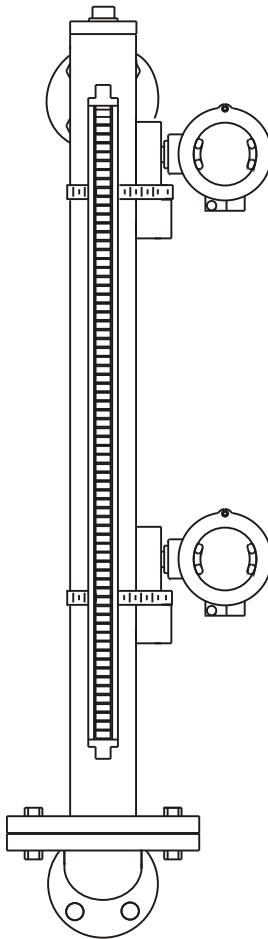

fig. 2

3. By-pass Level Indicator with adjustable magnetic switches and SUS304 ruler. It can be assembled with upward /downward movable multiple magnetic switches on a riding rod.

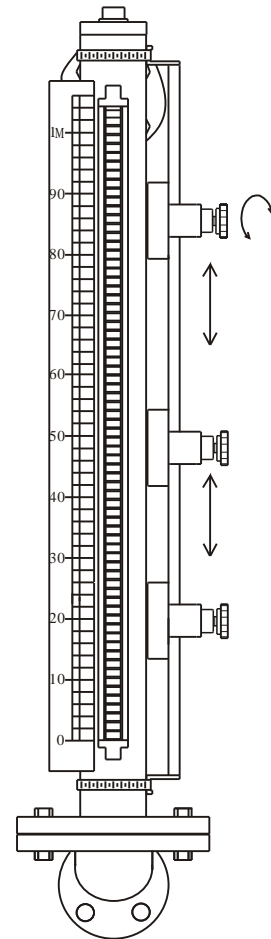

fig. 3

# CAUTIONS FOR INSTALLATION

1. The magnetic switch (EFB-14□□ series) is to be placed on a riding rod, then fasten the riding rod to the chamber with two hose clamps. (see page 18 - fig.3)
2. The magnetic switch (EFB-12□□ & EFB-13□□) is to be fastened on the chamber with a hose clamp. (see fig.4 and page 18 - fig.1, fig.2) Positioning orientation of magnetic switches as fig.2.
3. Because the magnetic switch is a sensitive component, thus any extreme shock to the switch will cause malfunction.
4. Make sure there is no external magnetic field or source within 10 centimeters of the switch to avoid magnetic interference.
5. Make sure the wire of the magnetic switch is pointing downward.
6. Do not contact any high temperature material with unit's cables while wiring.
7. When using magnetic switch to control inductive or capacitive load, a RC protective circuit should be used to ensure long life of the switch contact.
8. The magnetic switch must be located near the flag display and the surface of it is as close to the outer chamber wall as possible.
9. Before actuating, be sure all wirings are done correctly.
10. See fig.3 for the installation direction of mounting holes
11. A fixed holder is recommended to be used in between center to center flanges when distance is beyond 1.5 meters. Maximum distance between two fixed holders or center flange to fixed holder can not exceed 1 meter for best stability. Fixed holders will be a custom-made accessory for different applications. To order, please fill out the request in order form as shown in fig 7.

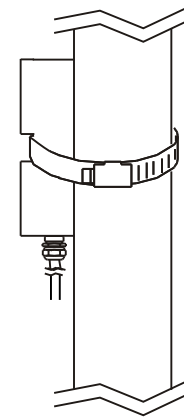

fig. 4

## Position Orientation Of Magnetic Switches

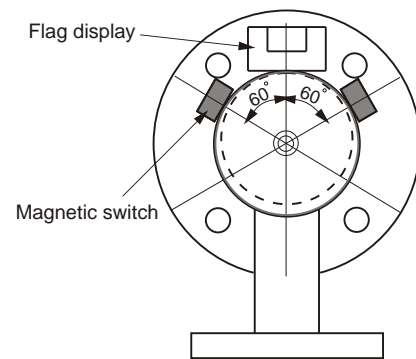

fig. 5

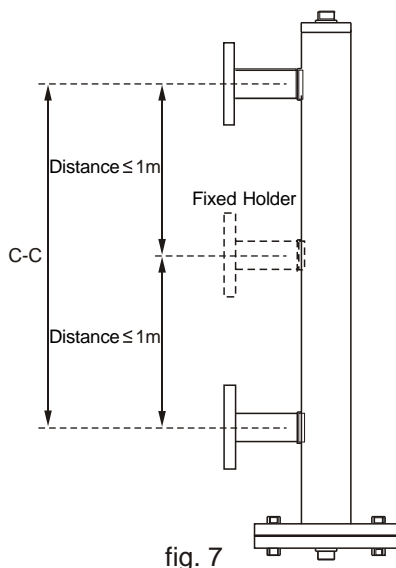

fig. 7

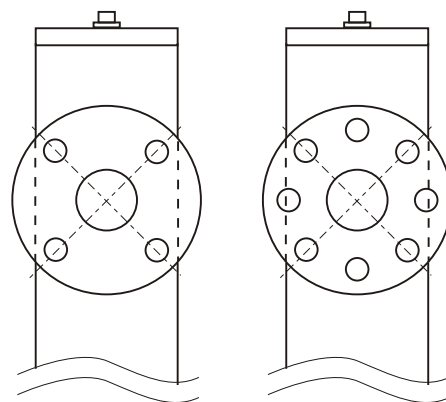

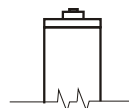

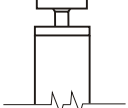
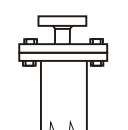
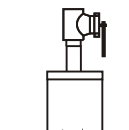
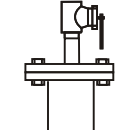
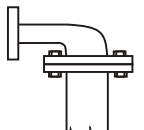

fig. 6

# ORDER INFORMATION

## Top End Type

<b>A</b> Cap	<b>B</b> Flat top +Plug	<b>C</b> Dual flange +Plug	<b>D</b> Flat top +Top mounting flange
			
<b>E</b> Dual flange +Top mounting flange	<b>F</b> Flat top +Control valve	<b>G</b> Dual flange +Control valve	<b>N</b> Dual flange +Angle pipe
			

## Connection

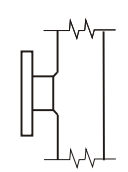
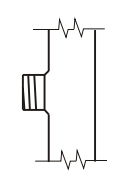
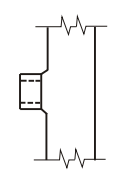
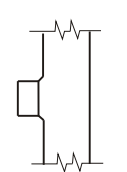
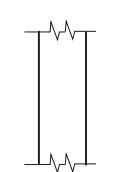
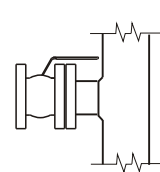
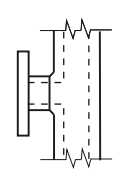
<b>1</b> Flange	<b>2</b> Screw (bolt type)	<b>3</b> Screw (nut type)	<b>4</b> Slip pipe	<b>5</b> N/A	<b>7</b> Control valve	<b>8</b> Jacket
						

## Bottom End Type

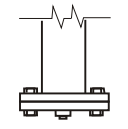
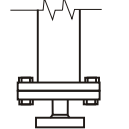
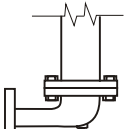
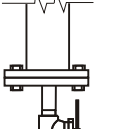
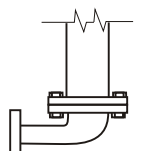
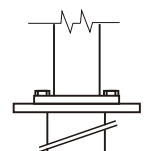
<b>H</b> Dual flange+Plug	<b>I</b> Dual flange +Top mounting flange	<b>J</b> Dual flange +Angel pipe+Plug	<b>K</b> Dual flange +Control valve
			
<b>L</b> Dual flange +Angle pipe	<b>M</b> Dual flange +Top mounting pipe		
			

# HOW TO MAKE YOUR ORDER

**Order No. EF** **C** **1** **1** **A** **1** **H** **1** **(J3)** **-** **05** ( ) ( )  
**Model No. BP** **C** **1** **1** **A** **1** **H** **1** **(J3)** **-** **05** ( ) ( )

**Float type** (see page 9, 10)

- |                      |                        |
|----------------------|------------------------|
| 1: EFB-2500 (PVDF)   | D: EFB-2600 (SUS316)   |
| 2: EFB-2510 (PP)     | E: EFB-2620 (TITANIUM) |
| 3: EFB-2540 (SUS316) | G: EFB-2630 (TITANIUM) |
| A: EFB-2560 (SUS316) | I: EFB-2592 (SUS316)   |
| C: EFB-2580 (SUS316) | K: EFB-2654 (TITANIUM) |
| S: Others            | --: None               |

**Material**

- |                            |                          |
|----------------------------|--------------------------|
| 1: SUS304 -- 140°C         | 8: SUS304 -- 200°C       |
| 2: SUS304 -- 400°C (350°C) | 9: SUS316 -- 200°C       |
| 3: SUS316 -- 140°C         | A: PP Coating -- 80°C    |
| 4: SUS316 -- 400°C (350°C) | B: PTFE Coating -- 120°C |
| 6: PP -- 80°C              | C: Removable Insulation  |
| 7: PVDF -- 120°C           | 400°C                    |
| ※: (350°C) with valve      | D: Heating Type -- 100°C |

**Flag Display** (see page 11)

- |                           |                           |
|---------------------------|---------------------------|
| 1: EFB - 0750 (-20~140°C) | 5: EFB - 0740 (-20~400°C) |
| 6: EFB - 0700 (-20~200°C) | 9: Other --: None         |

**End / Connection type** (see page 20)

**Top end Type**

- A: Cap
- B: Flat top+Plug
- C: Dual flange+Plug
- D: Flat top  
+Top mounting flange
- E: Dual flange  
+Top mounting flange
- F: Flat top+Control valve
- G: Dual flange+Control valve
- N: Dual flange+angle pipe
- S: other

**Connection**

- 1: Flange
- 2: Screw (bolt type)
- 3: Screw (nut type)
- 4: Slip pipe
- 5: N/A
- 7: Control valve
- 8: Jacket
- S: other

**Bottom end Type**

- H: Dual flange+Plug
- I: Dual flange  
+Top mounting flange
- J: Dual flange+angel pipe  
+Plug
- K: Dual flange+control valve
- L: Dual flange+angle pipe
- M: Dual flange  
+Top mounting pipe
- S: other

**Operating Pressure range**

- |                             |                                    |                             |
|-----------------------------|------------------------------------|-----------------------------|
| 1: -1~ 10kg/cm <sup>2</sup> | 2: -1~ 25kg/cm <sup>2</sup>        | 3: -1~ 50kg/cm <sup>2</sup> |
| 4: -1~100kg/cm <sup>2</sup> | 5: 0~5kg/cm <sup>2</sup> (Plastic) |                             |

**Magnetic Switch** (see page 15) **Quantity** 1~ 4

- |              |              |              |              |              |
|--------------|--------------|--------------|--------------|--------------|
| A: EFB -1220 | D: EFB -1260 | G: EFB -1400 | J: EFB -1430 | M: EFB -1350 |
| B: EFB -1230 | E: EFB -1300 | H: EFB -1410 | K: EFB -1450 | N: EFB -1360 |
| C: EFB -1250 | F: EFB -1310 | I: EFB -1420 | L: EFB -1440 |              |

\*Omit these two codes if no magnetic switch required.

**Length (Unit: m)**

- 05: below 0.5m    10: 0.5~1m    15: 1~1.5m . . .    \*0.5m per Unit

**Transducer**

Housing: G, K, L, N, X    \*Omit this code if no transducer required.

**Ruler**

Metal: M    Plastic: P    \*Omit this code if no ruler required.